

Circular saw - 3 601 F6D 010 - CSW41

www.powertools-aftersaleservice.com



BOSCH

Item	Part Number	Description	Illustration	Price	Quantity	Price Group
2	1 619 P08 102	Field 115V	1	-,-	1	-
3	1 619 P08 002	Armature 115V	1	-,-	1	-
4	1 619 X08 724	Switch	1	-,-	1	-
5	1 619 X08 527	Power supply cord	1	-,-	1	-
6	1 619 X08 308	Grommet	1	-,-	1	-
7	1 619 X04 671	Cable Clip	1	-,-	1	-
13	2 610 024 748	Ball Bearing	1	-,-	1	22
14	1 619 X04 676	Ball Bearing	1	-,-	1	-
16	1 619 X04 708	Brush Holder	1	-,-	2	-
20	1 619 X08 041	Warning Plate	1	-,-	1	-
22	1 619 X08 715	Hood	1	-,-	1	-
23	1 619 X01 249	Washer	1	-,-	1	18
24	1 619 X04 683	Washer	1	-,-	1	-
25	1 619 X04 684	Oil Drain Plug	1	-,-	1	-
26	1 619 X03 643	Collar bolt	1	-,-	1	-
27	1 619 X01 262	Stud	1	-,-	1	-
28	1 619 X08 910	Lower guard	1	-,-	1	-
29	1 619 X07 727	Handle	1	-,-	1	-
31	2 610 017 875	Ball Bearing	1	-,-	1	20
32	2 610 901 971	Screw	1	-,-	1	10
33	1 619 X04 765	Extension Spring	1	-,-	1	-
35	2 610 319 494	End stop	1	-,-	1	12
36	2 610 341 359	Spring retaining ring	1	-,-	1	12
38	1 619 X07 730	Upper guard	1	-,-	1	-
39	1 619 X07 688	Lever	1	-,-	1	-
40	1 619 X08 714	Auxiliary Handle	1	-,-	1	-
42	1 619 X01 253	Bearing Plate	1	-,-	1	-
43	1 619 X01 255	Guard Plate	1	-,-	1	-
45	1 619 X04 783	Cover	1	-,-	1	-
46	1 619 X01 268	Device cap	1	-,-	2	10
47	1 619 X04 712	O-Ring	1	-,-	1	-
48	1 619 X04 780	Collar	1	-,-	1	-
51	2 610 004 341	Washer	1	-,-	1	11

Item	Part Number	Description	Illustration	Price	Quantity	Price Group
52	2 610 912 616	Washer	1	-,-	3	10
53	2 610 968 747	Spring retaining ring	1	-,-	2	10
54	1 619 X04 719	Locking Lever	1	-,-	2	-
55	2 610 017 348	Deep-Groove Ball Bearing	1	-,-	2	23
56	2 610 027 039	Set screw	1	-,-	2	-
57	2 610 315 299	Screw	1	-,-	2	11
58	2 610 315 380	Screw	1	-,-	4	11
59	1 619 X03 644	Screw	1	-,-	1	-
60	1 619 X06 222	O-Ring	1	-,-	1	-
62	1 619 X07 724	Washer	1	-,-	1	-
63	2 610 329 955	Screw	1	-,-	3	11
64	1 619 X01 786	Contact Screw	1	-,-	4	10
65	2 610 306 355	Washer	1	-,-	3	11
66	1 619 X01 263	Stud	1	-,-	1	-
68	2 610 932 332	Screw	1	-,-	3	-
69	2 610 932 460	Self-locking nut	1	-,-	1	10
71	2 610 027 002	Screw	1	-,-	5	11
72	2 610 911 837	Bolt	1	-,-	1	10
73	2 610 004 459	Spring Washer	1	-,-	2	11
74	1 619 X01 257	Rubber Gasket	1	-,-	1	-
75	1 619 X07 731	Seal	1	-,-	1	-
78	1 619 X04 740	Seal	1	-,-	1	-
79	1 619 X04 738	Screw	1	-,-	4	-
80	1 619 X06 749	Screw	1	-,-	1	10
81	1 619 X04 754	Screw	1	-,-	2	-
82	1 619 X01 258	Gasket	1	-,-	1	-
83	1 619 X05 847	Washer	1	-,-	1	-
84	2 610 318 324	Nut	1	-,-	1	11
85	1 619 X08 712	Special Nut	1	-,-	1	-
86	1 619 X04 746	Screw	1	-,-	4	-
87	1 619 X06 242	Bushing	1	-,-	1	-
88	1 619 X06 254	Washer	1	-,-	1	-
90	1 619 X05 948	Bearing Cover	1	-,-	1	-
91	1 619 X06 749	Screw	1	-,-	4	10
92	2 610 932 218	Screw	1	-,-	1	11
93	1 619 X01 283	Nut	1	-,-	2	14
107	2 610 911 889	Set screw	1	-,-	1	-
310	1 619 X04 768	Set screw	1	-,-	1	-
320	1 619 X04 669	Spring	1	-,-	1	-
651	1 619 X04 755	Socket wrench	1	-,-	1	-
801	1 619 X08 036	Motor Housing	1	-,-	1	-
808	1 619 X08 039	Nameplate	1	-,-	1	-
810	1 619 X07 410	Carbon-Brush Set	1	-,-	1	-
819	1 619 X06 299	Gear Housing	1	-,-	1	-
830	1 619 X08 044	Base Plate	1	-,-	1	-
834	1 619 X07 035	Set Of Gears	1	-,-	1	-
870	1 616 B10 364	O-Ring	1	-,-	1	-

Product information Circular saw - 3 601 F6D 010 - CSW41

Product No	3 601 F6D 010
Description	263.656; Circular saw
DIN-Text	
ID_Text_Ext	0
Trading_Description	CSW41
Voltage_1	115 V
ID_Country_Product	USA

Illustration - Type E

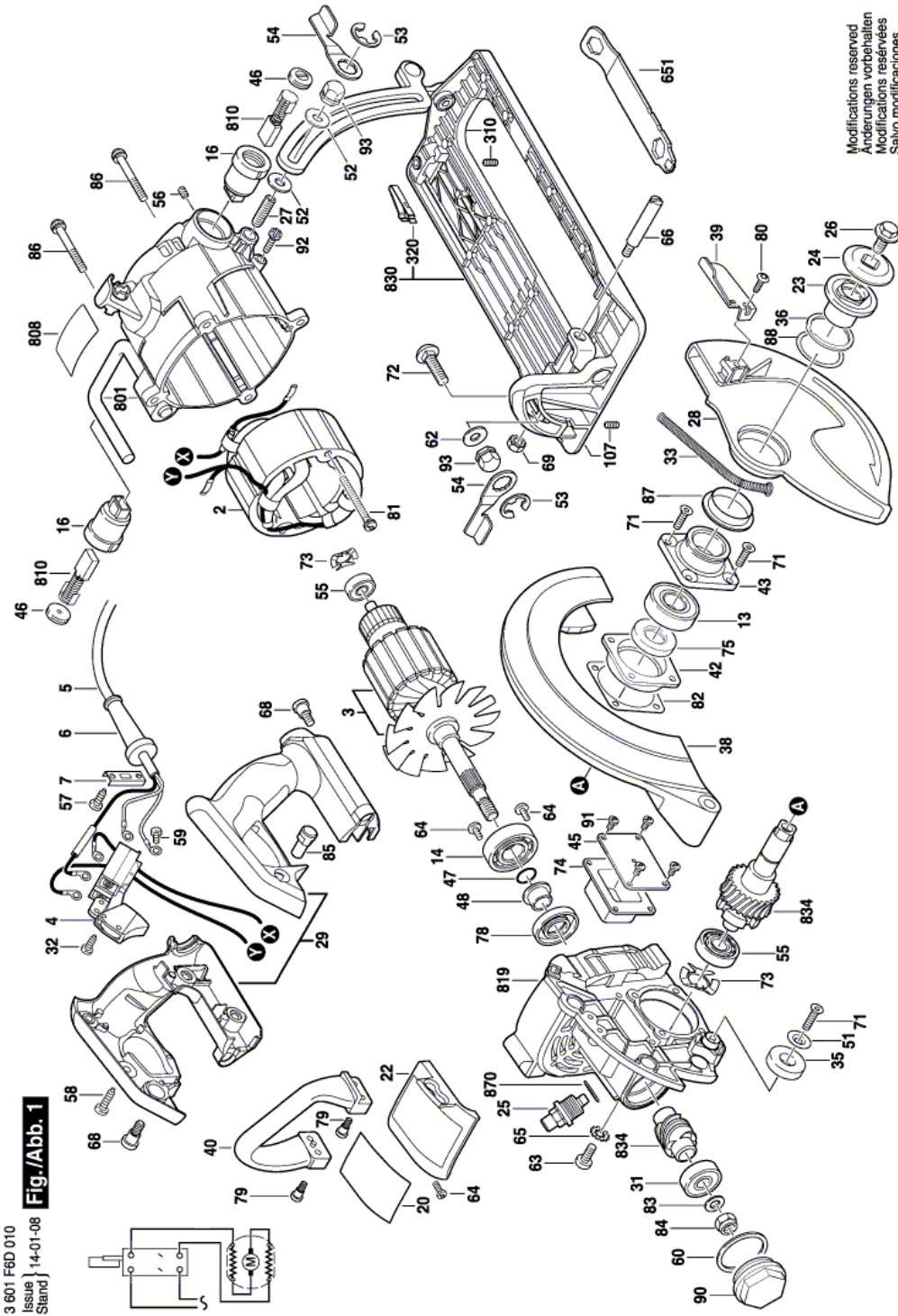

Information subject to change without further notice.