



# SERVICE PARTS LIST

BUL. 54-06-0302

1/4" SPEED CONTROL DRILL

REVISED BUL 54-06-0301 DATE May '68

Catalog No. 0102

Starting Serial No. 402-5506

WIRING INSTR. 58-01-0040

Both Model and Serial No. must be furnished to obtain correct parts.

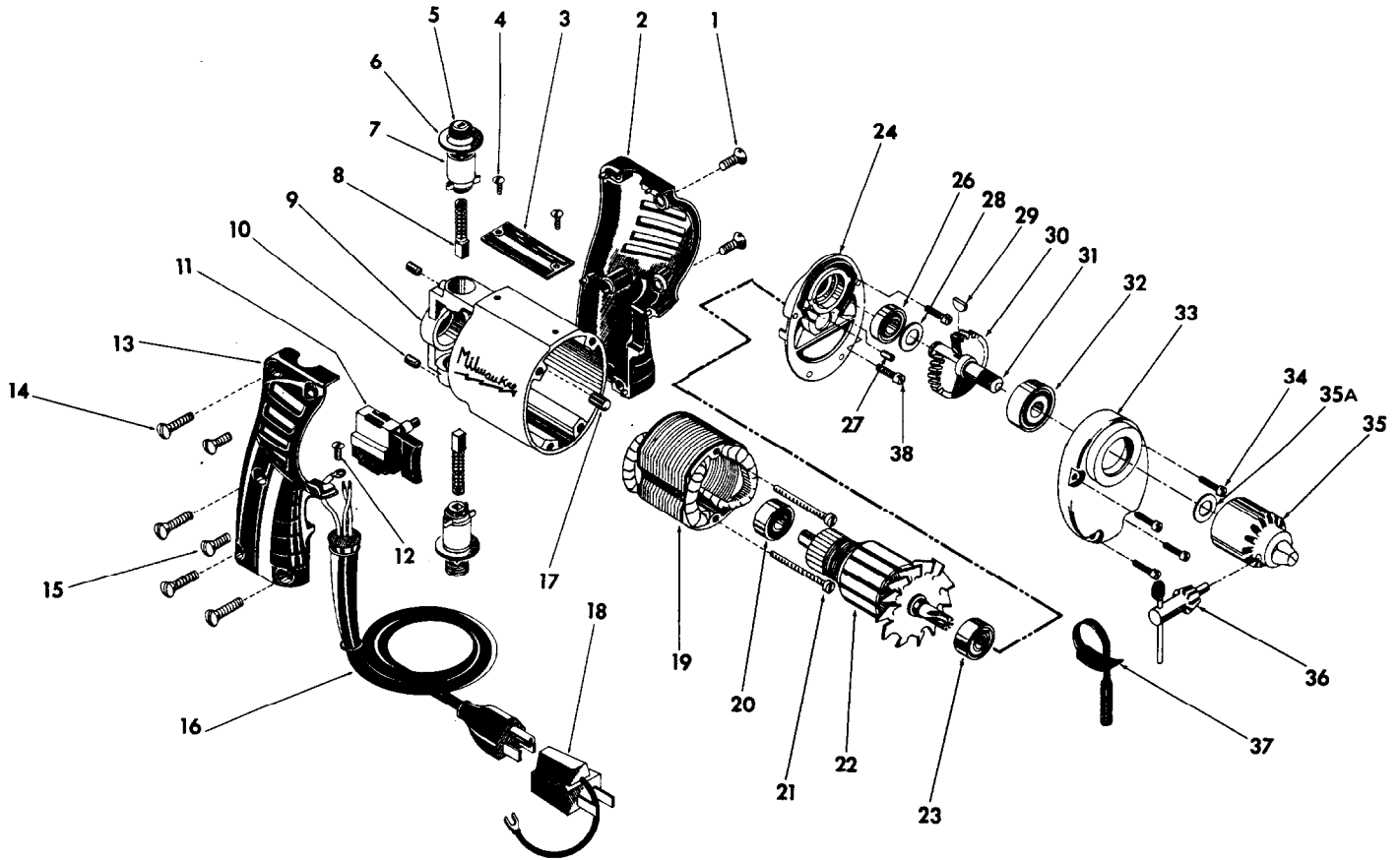

## ILLUSTRATED PARTS

FIG.	PART NO.	DESCRIPTION OF PART	FIG.	PART NO.	DESCRIPTION OF PART
1	06-81-3600	8-32x3/8 Oval Hd. Handle Mtg. Scr. (2)	20	02-04-0740	Ball Bearing
2	31-44-0111	L.H. Handle Half	21	06-81-5950	6-32x1-7/8 Fil.Hd. Field Screws (2)
3	12-98-0600	Name Plate	22	16-22-1280	Armature Assy.
4	06-81-4300	3-48x3/16 Rd.Hd. Name Plate Scr. (2)	23	02-04-0880	Ball Bearing
5	23-44-0020	Brush Retaining Cap (2)	24	28-28-0941	Diaphragm
6	23-86-0070	Insulating Washer (2)	26	02-08-0375	Ball Bearing
7	22-22-0251	Brush Holder Assy. (2)	27	45-30-0070	Ball Bearing Retaining Slug
8	22-18-0360	Carbon Brush Assy. (2)	28	45-88-0250	Washer
9	28-50-6091	Motor Housing Assy.(Incl. Item 17)	29	06-42-0400	Woodruff Key
10	06-83-0100	10-32x1/4 Hd'less Slotted Br.Hd. Scr. (2)	30	32-75-1901	Spindle Gear
11	23-66-0600	Speed Control Switch	★ 31	38-50-5021	Spindle
12	06-81-8625	6-32x1/4 (Bronze) Rd.Hd. Ground Scr.	★ 32	02-04-1040	Ball Bearing
13	31-44-0100	R.H. Handle Half	★ 33	28-14-1331	Gear Case
14	06-81-3650	8-32x3/4 Oval Hd. Handle Mtg. Scr. (4)	34	06-81-6300	8-32x7/8 Fil.Hd. Sems Gear Case Scr. (4)
15	06-81-3600	8-32x3/8 Oval Hd. Handle Mtg. Scr. (2)	35	48-66-0260	Chuck
16	22-64-0450	Cord Set	36	48-66-3200	Chuck Key
17	45-30-0120	Ball Bearing Ret. Slug	37	48-56-4080	Key Holder
18	48-03-0010	Attachment Plug Adaptor (Except in Canada)	38	06-81-6150	8-32x1/2 Fil. Hd. Sems Diaphragm Scr. (2)
19	18-22-1121	Field			