



SERVICE PARTS LIST

BULLETIN NO.
54-06-0750

SPECIFY CATALOG NO. AND SERIAL NO. WHEN ORDERING PARTS		REVISED BULLETIN	DATE
12 VOLT 1/4" PISTOL DRILL			July '82
CATALOG NO. 0135	STARTING SERIAL NO. 614-1001	WIRING INSTRUCTION 58-01-0135	
CAT. NO.	START SER. NO.	BILINGUAL LABEL	

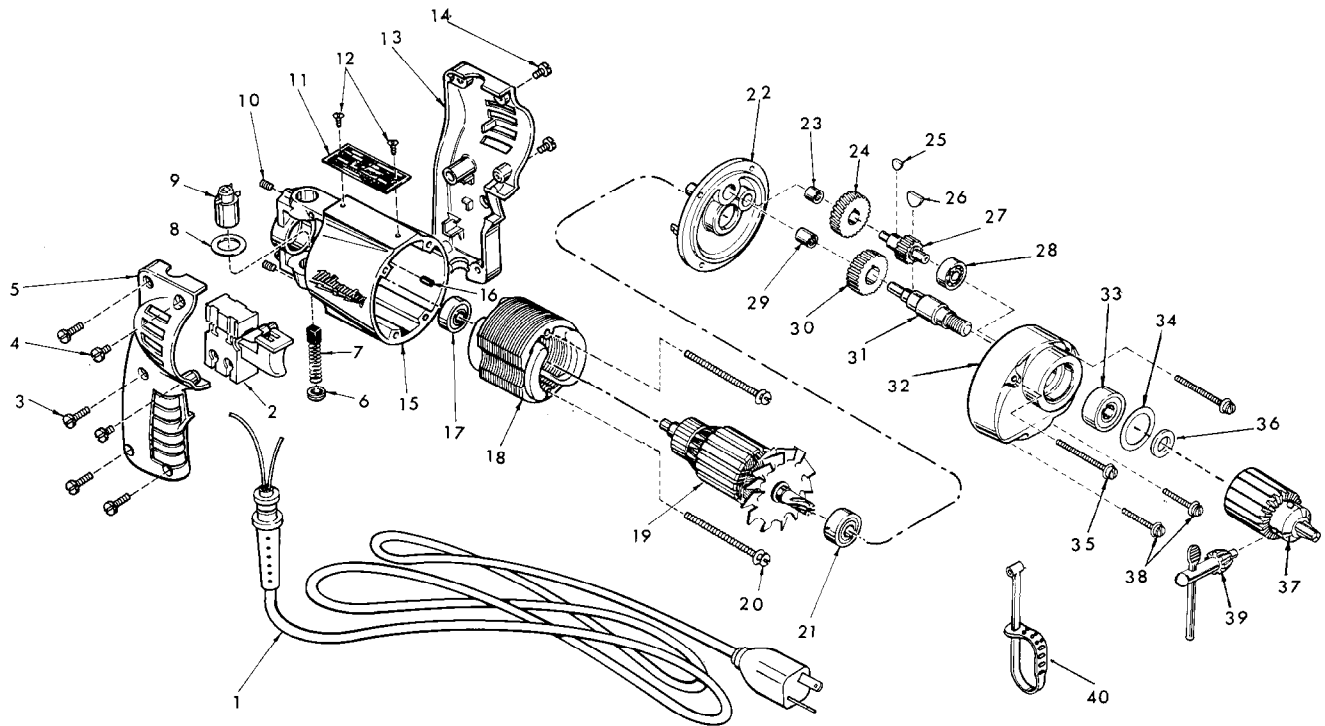

FIG.	PART NO.	DESCRIPTION OF PART	NO. REQ.	FIG.	PART NO.	DESCRIPTION OF PART	NO. REQ.
1	22-64-0315	Cord Set	(1)	22	28-28-0221	Diaphragm	(1)
2	23-66-0805	Switch	(1)	23	02-50-1210	Needle Bearing	(1)
3	06-81-0402	8-32x3/4" Pan Hd. Screw	(4)	24	32-40-1041	Intermediate Gear	(1)
4	06-81-0452	8-32x3/8" Pan Hd. Screw	(2)	25	06-42-0400	Woodruff Key	(1)
5	31-44-0252	R. H. Handle Half	(1)	26	06-42-0800	Woodruff Key	(1)
6	23-44-0020	Brush Retaining Cap	(2)	27	36-66-1151	Intermediate Pinion Shaft	(1)
7	22-18-0600	Carbon Brush Assembly	(2)	28	02-04-0640	Ball Bearing	(1)
8	23-86-0105	Insulating Washer	(2)	29	02-50-1640	Needle Bearing	(1)
9	22-22-1251	Brush Holder Assembly	(2)	30	32-75-1181	Spindle Gear	(1)
10	06-83-2430	10-32x1/4" Skt. Hd. Set Screw	(2)	31	38-50-1051	Spindle	(1)
11	12-99-0025	Nameplate Blank	(1)	32	28-14-0363	Gear Case (Incl. 06-65-0825 Groove Pin)	(1)
12	06-85-0200	Nameplate Screw	(2)	33	02-04-1020	Ball Bearing	(1)
13	31-44-0262	L. H. Handle Half	(1)	34	34-80-1400	Retaining Ring	(1)
14	06-81-0452	8-32x3/8" Pan Hd. Screw	(2)	35	06-81-6575	8-32x1-5/8" Fil. Hd. Sem	(2)
15	28-50-6096	Motor Housing (Includes Fig. No. 16)	(1)	36	45-88-0080	Chuck Washer	(1)
16	45-30-0120	Ball Bearing Retaining Slug	(1)	37	48-66-0260	1/4" Chuck	(1)
17	02-04-0740	Ball Bearing	(1)	38	06-81-6350	8-32x1" Fil. Hd. Sem	(2)
18	18-20-1100	12 Volt Field	(1)	39	48-66-3200	Chuck Key	(1)
19	16-20-1010	12 Volt Armature	(1)	40	48-66-4080	Key Holder	(1)
20	06-81-5950	6-32x1-7/8" Fil. Hd. Screw	(2)	41	10-98-5986	Warning Label (Not Shown)	(1)
21	02-04-0880	Ball Bearing	(1)	42	10-98-5891	12 Volt Label (Not Shown)	(1)