



# SERVICE PARTS LIST

## 3/8" PISTOL DRILL

Catalog No. **0221**

Starting Serial No. **378-37100**

Specify Catalog and Serial No. when ordering parts

**BUL. 54-06-2105**

REVISED BUL.  
54-06-2104

DATE  
FEB '78

WIRING INSTRUCTIONS  
**58-01-0648**

650 R.P.M.  
3.3 AMPS

FOR CAT. NO. 0221-2  
(240V) TOOL USE:

- 22-18-0375 CARBON BRUSH
- 18-16-0050 FIELD
- 16-16-0320 ARMATURE
- 22-64-4200 CORD SET

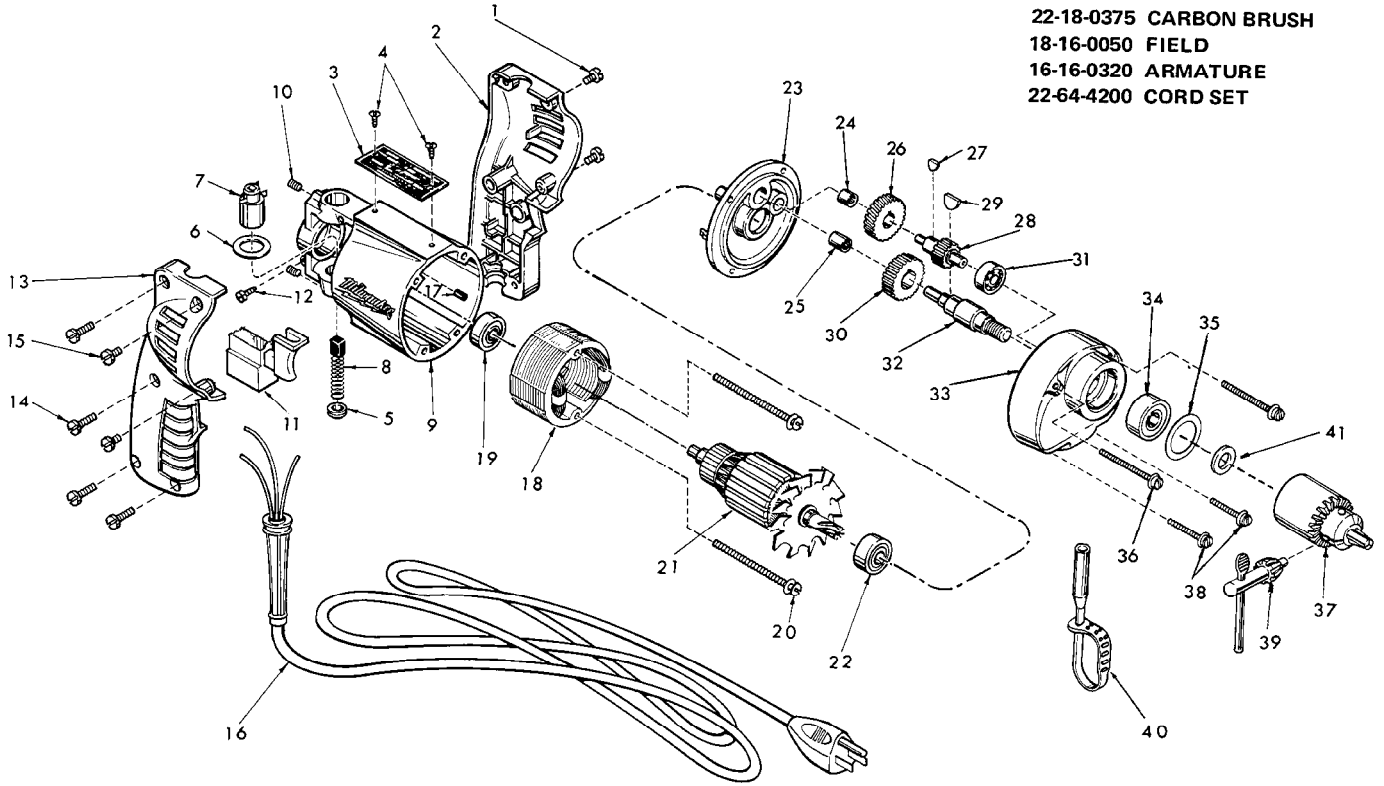

FIG.	PART NO.	DESCRIPTION OF PART	NO. REQ.	FIG.	PART NO.	DESCRIPTION OF PART	NO. REQ.
1	06-81-0452	8-32x3/8 Pan Hd. Screw	(2)	22	02-04-0740	Ball Bearing	(1)
2	31-44-0620	L.H. Handle Half	(1)	23	28-28-0221	Diaphragm	(1)
3	12-99-0020	Nameplate Blank	(1)	24	02-50-1210	Needle Bearing	(1)
4	06-85-0200	Nameplate Screw	(2)	25	02-50-1640	Needle Bearing	(1)
5	23-44-0020	Brush Retaining Cap	(2)	26	32-40-1121	Intermediate Gear	(1)
6	23-86-0105	Insulating Washer	(2)	27	06-42-0400	Woodruff Key	(1)
7	22-22-1251	Brush Holder Assy.	(2)	28	36-66-0851	Intermediate Pinion Shaft	(1)
8	22-18-0155	Carbon Brush Assy.	(2)	29	06-42-0800	Woodruff Key	(1)
9	28-50-6091	Motor Housing (Incl. Fig. No. 17)	(1)	30	32-75-1101	Spindle Gear	(1)
10	06-83-2430	10-32x1/4 Soc. Hd. Set Screw	(2)	31	02-04-0640	Ball Bearing	(1)
11	23-66-0515	Switch	(1)	32	38-50-1051	Spindle	(1)
12	06-81-8625	Ground Screw	(1)	33	28-14-0363	Gear Case	(1)
13	31-44-0610	R.H. Handle Half	(1)	34	02-04-1020	Ball Bearing	(1)
14	06-81-0402	8-32x3/4 Pan Hd. Screw	(4)	35	34-80-1400	Retaining Ring	(1)
15	06-81-0452	8-32x3/8 Pan Hd. Screw	(2)	36	06-81-6575	8-32x1-5/8 Fil. Hd. Sems	(2)
16	22-64-0665	Cord Set	(1)	37	48-66-0800	Chuck	(1)
17	45-30-0120	Ball Bearing Ret. Slug	(1)	38	06-81-6350	8-32x1 Fil. Hd. Sems	(2)
★ 18	18-10-0050	Field	(1)	39	48-66-3080	Chuck Key	(1)
19	02-04-0740	Ball Bearing	(1)	40	48-66-4040	Key Holder	(1)
★ 20	06-81-5935	6-32x1-3/4 Fil. Hd. Screw	(2)	41	45-88-0080	Chuck Washer	(1)
★ 21	16-10-0320	Armature Assy.	(1)	42	12-98-7081	Caution Plate (Not Shown)	(1)