



SERVICE PARTS LIST

BULLETIN NO.
54-10-0545

SPECIFY CATALOG NO. AND SERIAL NO. WHEN ORDERING PARTS		REVISED BULLETIN 54-10-0544	DATE Oct. '82
1/2" ELECTRIC DRILL			
CATALOG NO. 1620-1	STARTING SERIAL NO. 343-15110		WIRING INSTRUCTION 58-01-0536
CAT. NO. 1620-6	START SER. NO. 343-15110	BILINGUAL LABEL 10-98-6400	

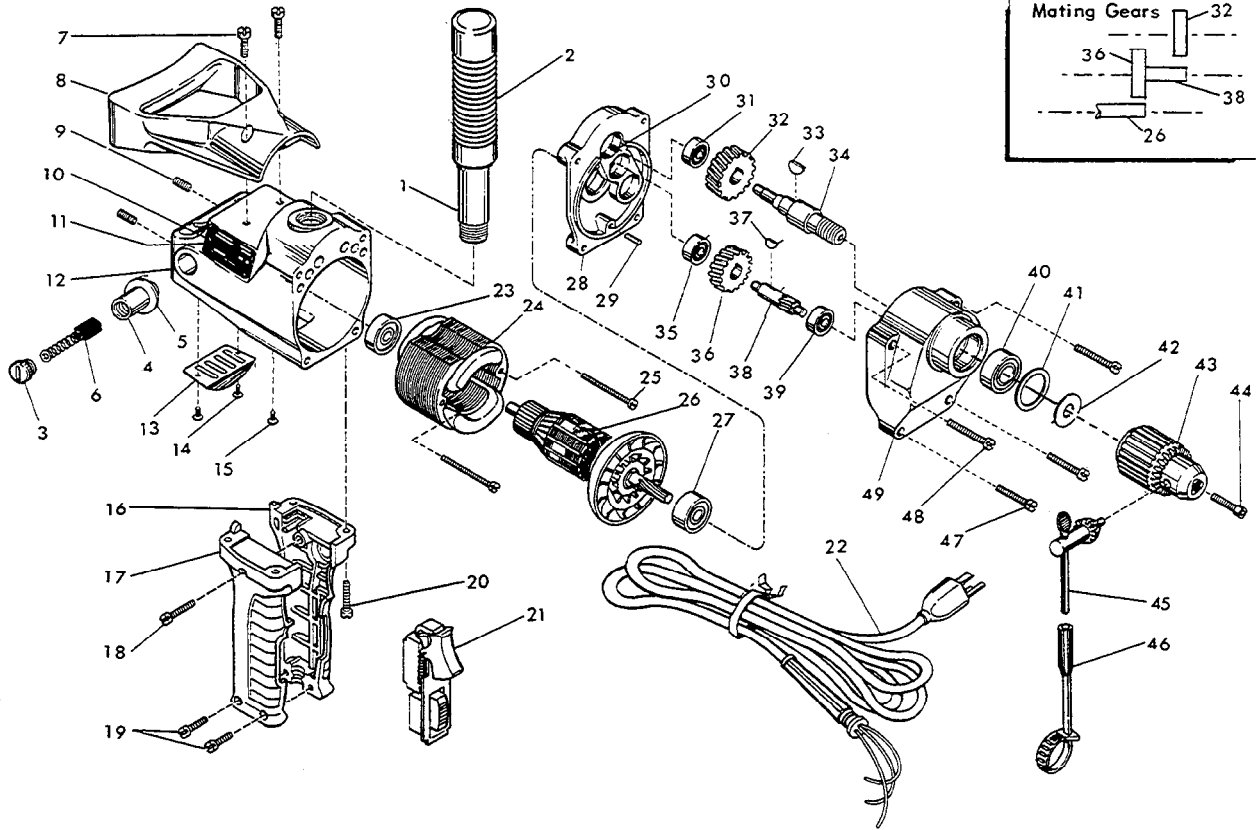

FIG.	PART NO.	DESCRIPTION OF PART	NO. REQ.	FIG.	PART NO.	DESCRIPTION OF PART	NO. REQ.
	1	43-62-0230 Pipe Handle	(1)	★ 26	16-62-1141	120 Volt Armature	(1)
★	2	43-62-0242 Handle Grip	(1)	27	02-04-1070	Ball Bearing	(1)
	3	23-44-0065 Brush Retaining Screw	(2)	28	28-28-0621	Diaphragm (Includes Fig. Nos. 29 & 30)	(1)
★	4	22-22-1120 Brush Holder	(2)	29	06-65-0625	3/16x1/2 Groove Pin	(1)
	5	23-86-0130 Fiber Washer	(2)	30	45-30-0060	Bearing Retaining Slug	(2)
	6	22-18-0170 Carbon Brush	(2)	31	02-04-0820	Ball Bearing	(1)
★	7	06-81-4213 12-24x5/8 Phillips Pan Hd. Screw	(2)	32	32-75-2101	Spindle Gear	(1)
★	8	31-44-1000 Spade Handle	(1)	33	06-42-2000	Woodruff Key	(1)
	9	06-83-2670 1/4-20x1/2 Knrl. Set Screw	(2)	34	38-50-2661	Spindle	(1)
	10	06-85-0200 6x1/4 Nameplate Screw	(2)	35	02-04-0820	Ball Bearing	(1)
	11	12-99-0010 Nameplate Blank	(1)	36	32-40-1261	Intermediate Gear	(1)
	12	28-50-4646 Motor Housing	(1)	37	06-42-1200	Woodruff Key	(1)
	13	44-56-0140 Cover Plate	(1)	38	36-66-3101	Intermediate Shaft	(1)
	14	06-81-8650 6-32x1/4 Rd. Hd. Sem	(2)	39	02-04-0820	Ball Bearing	(1)
	15	06-81-8625 6-32x1/4 Ground Screw	(1)	40	02-04-1650	Ball Bearing	(1)
★	16	31-44-0510 Left Handle Half	(1)	41	34-80-2500	Retaining Ring	(1)
★	17	31-44-0500 Right Handle Half	(1)	42	45-88-0330	Chuck Spacer Washer	(1)
★	18	06-81-6402 8-32x1-1/8 Fil. Hd. Sem	(1)	43	48-66-1380	1/2" Rev. Chuck (Includes Fig. No. 45)	(1)
★	19	06-81-6202 8-32x5/8 Fil. Hd. Sem	(2)	44	06-75-3150	1/4-20x1 Skt. Cap Screw L.H. Thread	(1)
★	20	06-81-7550 12-24x3/4 Fil. Hd. Sem	(4)	45	48-66-3280	Chuck Key	(1)
★	21	23-66-0581 Reversing Switch	(1)	46	48-66-4040	Key Holder	(1)
★	22	22-64-0387 Cord Set	(1)	47	06-81-7450	10-32x1-3/16 Fil. Hd. Sem	(2)
	23	02-04-0970 Ball Bearing	(1)	48	06-81-7460	10-32x1-7/16 Fil. Hd. Sem	(2)
	24	18-62-1120 120 Volt Field	(1)	49	28-14-0721	Gear Case	(1)
	25	06-81-6700 8-32x1-7/8 Fil. Hd. Sem	(2)	★ 50	10-98-5987	Caution Label (Not Shown) Omit For Canadian Tools	(1)

MILWAUKEE ELECTRIC TOOL CORPORATION
13135 W. LISBON RD., BROOKFIELD, WIS. 53005