



# SERVICE PARTS LIST

**BULLETIN NO.**  
**54-22-1026**

SPECIFY CATALOG NO. AND SERIAL NO. WHEN ORDERING PARTS		REVISED BULLETIN	DATE
<b>D. I. DIE GRINDER</b>		54-22-1025	Oct. 2012
<b>CATALOG NO.</b>	<b>5192</b>	<b>WIRING INSTRUCTION</b>	
	<b>STARTING SERIAL NO.</b>	<b>58-01-0309</b>	
	<b>669C</b>		

**EXAMPLE:**  

00	0
----	---

 Component Parts (Small #) Are Included When Ordering The Assembly (Large #).

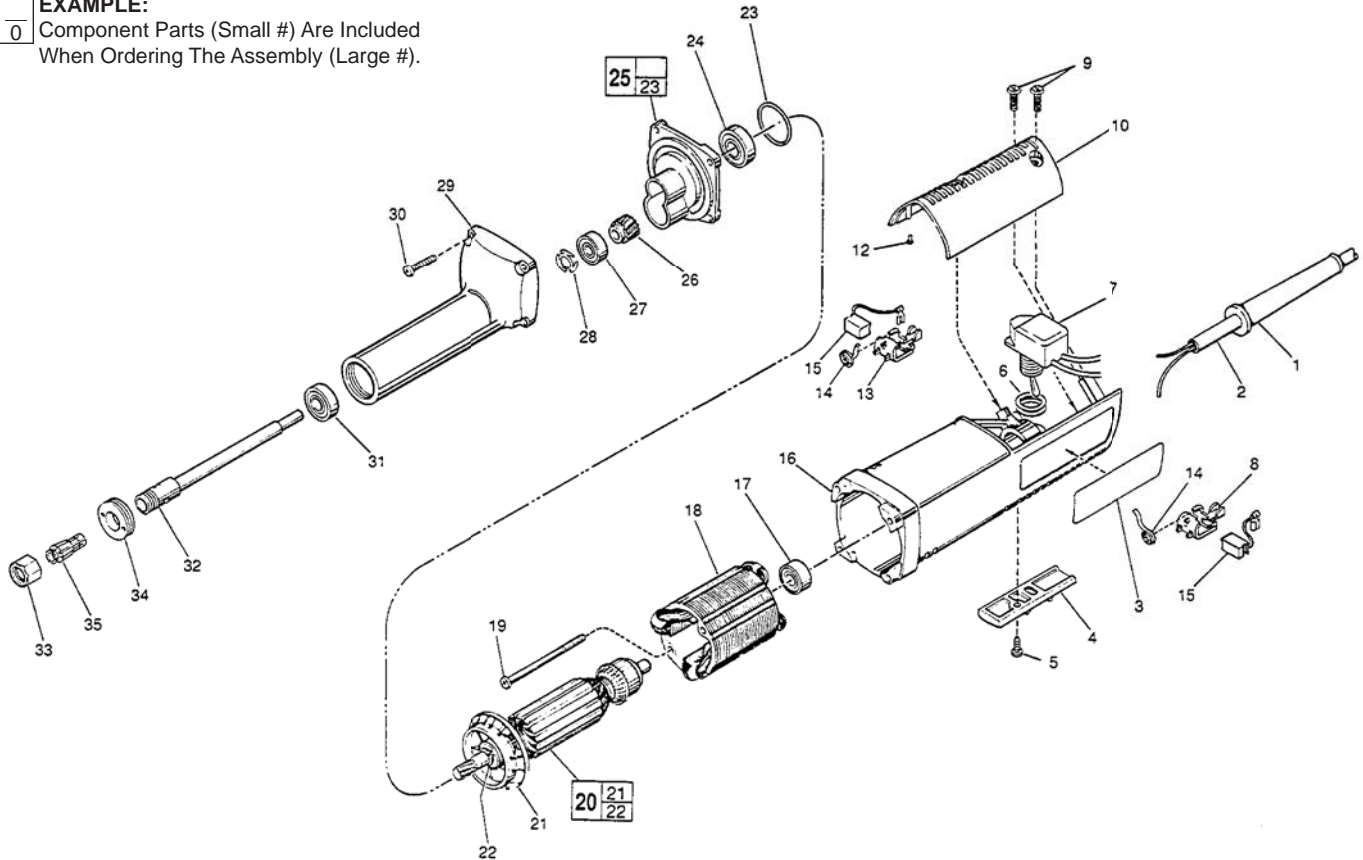

FIG.	PART NO.	DESCRIPTION OF PART	NO. REQ.
1	44-76-0130	Cord Protector	(1)
2	22-64-0215	Cord Set	(1)
3	12-20-0900	Service Nameplate Kit	(1)
4	31-55-0156	Trigger Cover	(1)
5	06-82-7409	8-16 x 1/2" Pan Hd. T-20 Plastite Screw	(1)
6	34-40-4015	O-Ring	(2)
7	23-66-2190	Switch	(1)
8	22-20-0691	Left Brush Holder	(1)
9	06-82-7270	8-16 x 5/8" Pan Hd. T-20 Plastite Screw	(3)
10	31-15-0143	Motor Housing Cover	(1)
12	42-38-0181	Rubber Bumper	(2)
13	22-20-0692	Right Brush Holder	(1)
14	23-52-0240	Brush Spring	(2)
15	22-18-0710	Carbon Brush	(2)
★16	31-50-0426	Motor Housing	(1)
17	02-04-0845	Ball Bearing	(1)
18	18-07-0100	120 Volt Field	(1)
19	06-82-7375	8-16 x 2-1/2" Pan Hd. Plast. T-20 Screw	(2)

FIG.	PART NO.	DESCRIPTION OF PART	NO. REQ.
20	16-07-0100	120 Volt Armature	(1)
21	22-84-0680	Fan	(1)
22	34-60-0920	Ball Brg. Retaining Ring	(1)
23	34-40-4210	O-Ring	(1)
24	02-04-1207	Ball Bearing	(1)
25	28-28-1905	Diaphragm Assembly	(1)
26	32-75-2880	Spindle Gear	(1)
27	02-04-0845	Ball Bearing	(1)
28	45-88-7550	Finger Washer	(1)
29	28-50-7718	Spindle Housing	(1)
★30	06-82-7296	7-18 x 1" Pan Hd. Slit. Plast. T-20 Screw	(4)
31	02-04-1005	Ball Bearing	(1)
32	38-50-5211	Spindle Shaft	(1)
33	48-68-0031	1/4" Collet Nut	(1)
34	44-40-0490	Bearing Lock Nut	(1)
35	48-66-0975	1/4" Collet	(1)
	49-96-4040	1/2" Open End Wrench (Not Shown)	(1)
	49-96-4090	11/16" Open End Wrench (Not Shown)	(1)

**FIG. LUBRICATION**

29 1/4 Oz. Type "G" Grease, No. 49-08-4140.