

SPECIFY CATALOG NO. AND SERIAL NO. WHEN ORDERING PARTS		REVISED BULLETIN	DATE
1-1/2" (40mm) ROTARY HAMMER			May 2008
CATALOG NO. 5315-21	STARTING SERIAL NO. 338A	WIRING INSTRUCTION 58-01-1850	

EXAMPLE:
 Component Parts (Small #) Are Included
 When Ordering The Assembly (Large #).

● = Component of the
 Hammer Service Kit
 No. 14-46-9265

**▲ SEE BACK PAGE OF THIS
 BULLETIN FOR ADDITIONAL
 LUBRICATION AND
 SERVICE NOTES**

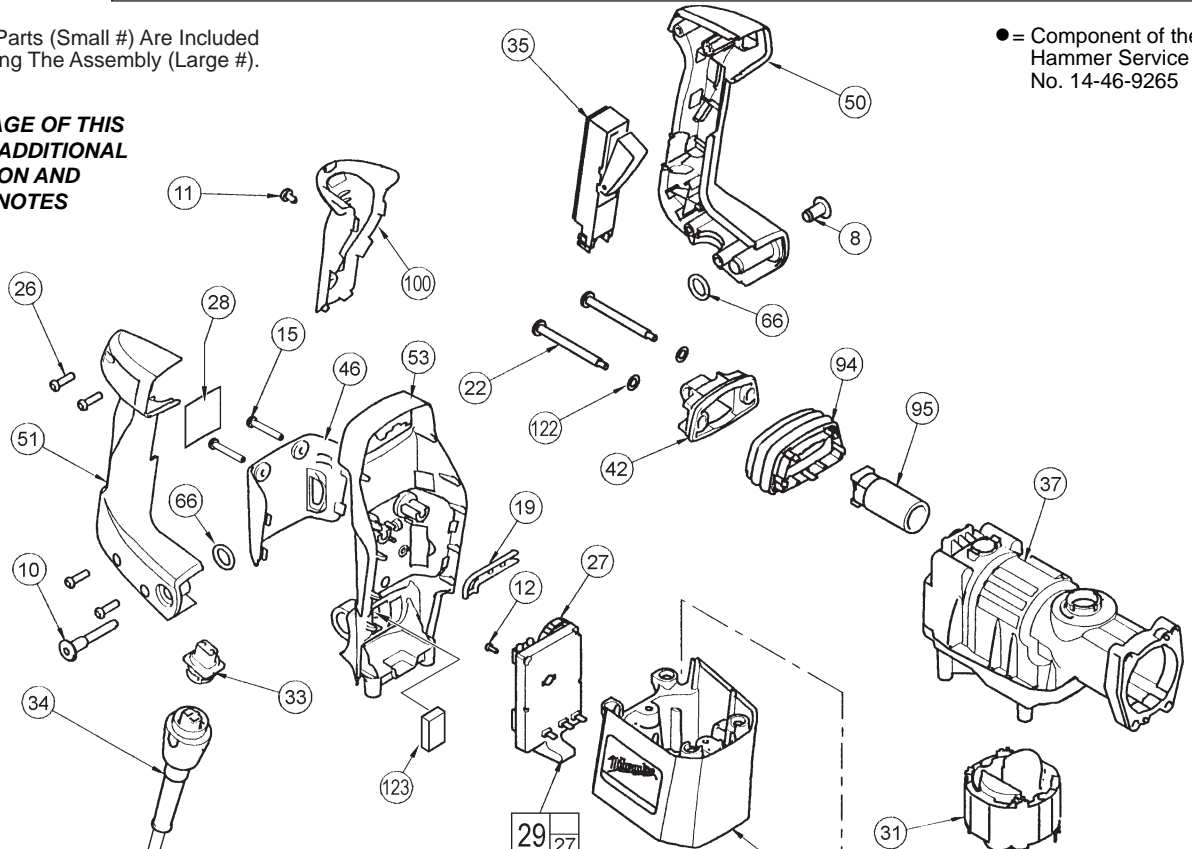
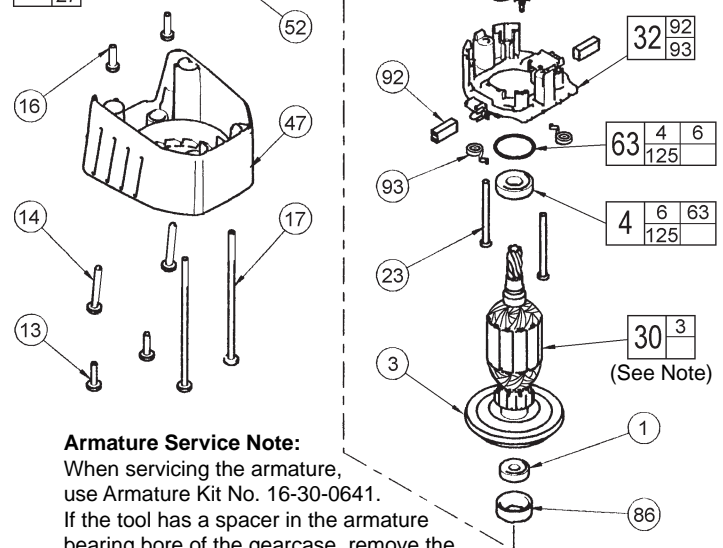
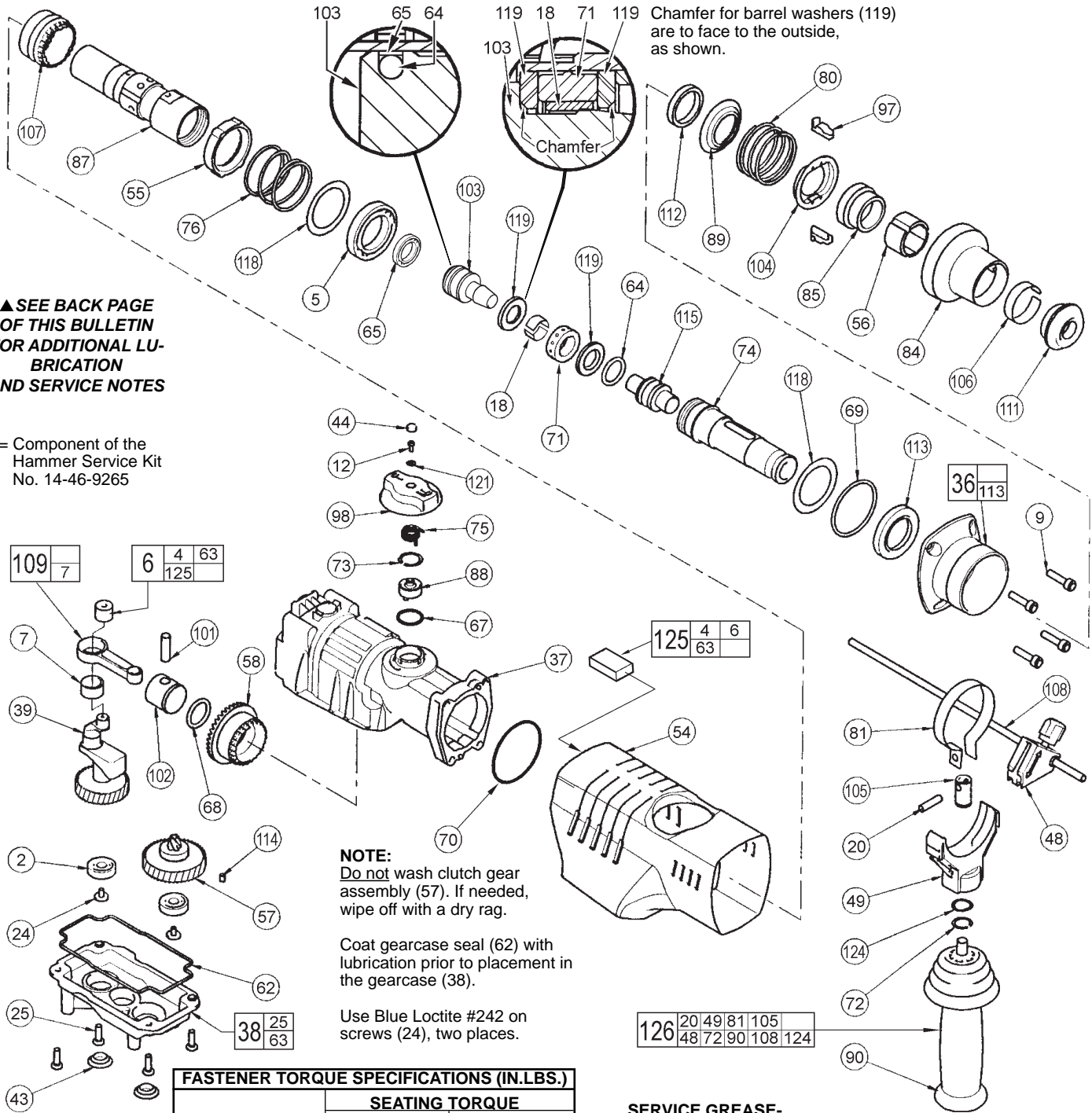

FIG.	PART NO.	DESCRIPTION OF PART	NO. REQ.
1	02-04-0845	Ball Bearing	(1)
3	22-84-0875	Fan	(1)
4	14-46-0040	Vent Kit	(1)
8	05-59-0100	Pivot Nut	(1)
10	05-77-0100	Pivot Bolt	(1)
11	05-88-3650	K50 x 8mm Pan Hd. Plastite Screw	(1)
12	05-88-5910	K35 x 8mm Pan Hd. Plastite Screw	(1)
13	05-88-5930	K60 x 20mm Pan Hd. Plastite Screw	(2)
14	05-88-5940	K60 x 40mm Pan Hd. Plastite Screw	(2)
15	05-88-9920	K50 x 30mm Pan Hd. PT-DG Screw	(2)
16	05-88-9930	K60 x 18mm Pan Hd. PT-DG Screw	(2)
17	05-88-9940	K60 x 120mm Pan Hd. PT-DG Screw	(2)
19	31-01-0065	Light Pipes	(1)
22	06-81-1805	Pan Hd. Cap Screw	(2)
23	06-82-7375	Slotted Plastite Torx Screw	(2)
26	06-95-6290	K50 x 18mm Pan Hd. Plastite Screw	(4)
27	31-01-0035	Thumbwheel	(1)
28	12-20-5315	Service Nameplate Kit	(1)
29	14-20-1070	Electronics Assembly	(1)
30	16-30-0641	Armature Kit (See Service Note)	(1)
31	18-30-1040	Field	(1)
32	22-22-1530	Brush Card Assembly	(1)
33	22-56-0042	Blade Housing Assembly	(1)
34	48-76-5010	Quik-Lok Cord Set	(1)
35	23-66-2195	Switch	(1)
37	28-14-2541	Crankcase Assembly	(1)
42	31-10-0140	Upper Handle Mount	(1)
46	31-15-0613	Module Cover	(1)
47	31-15-2053	Motor Cover	(1)
50	31-44-2211	Left Handle Half	(1)
51	31-44-2221	Right Handle Half	(1)
52	31-50-5101	Motor Housing	(1)
53	31-55-0281	Rear Shroud	(1)
63	14-46-0040	Vent Kit	(1)
66	34-40-4490	O-Ring	(2)
86	42-96-0125	● Bearing Cup	(1)



Armature Service Note:
 When servicing the armature, use Armature Kit No. 16-30-0641. If the tool has a spacer in the armature bearing bore of the gearcase, remove the spacer and install O-Ring No. 34-40-4215 into the empty groove. The O-Ring is provided in the kit.

FIG.	PART NO.	DESCRIPTION OF PART	NO. REQ.
92	22-18-1355	● Carbon Brush Kit (Includes 2 Brushes)	(1)
93	40-50-2220	Brush Spring	(2)
94	43-87-0035	Bellows	(1)
95	43-87-0060	Isolation Module Assembly	(1)
100	44-52-0590	Cushion Grip	(1)
122	45-88-8555	Rubber Washer	(2)
123	45-06-0535	Handle Seal	(1)



▲SEE BACK PAGE OF THIS BULLETIN FOR ADDITIONAL LUBRICATION AND SERVICE NOTES

● = Component of the Hammer Service Kit No. 14-46-9265

FASTENER TORQUE SPECIFICATIONS (IN.LBS.)

FIG. NO.	SEATING TORQUE	
	MINIMUM	MAXIMUM
9	120	140
10	20	25
11	3	6
12	4	8
13	20	25
14	20	25
15	15	20
16	50	55
17	30	35
22	30	35
23	12	17
24	20	25
25	45	50
26	15	20
74	130 FT. LBS.	200 FT. LBS.
87	130 FT. LBS.	200 FT. LBS.
Switch Screws	4	6

SERVICE GREASE-

● "S2" Grease, No. 49-08-5265 7 oz. tube

● **14-46-9265 HAMMER SERVICE KIT**

THIS KIT CONTAINS:

- | | | |
|---|------------|------------------------|
| 2 | 31-12-0040 | Cap Plug |
| 1 | 34-40-0240 | Gearcase Seal |
| 2 | 34-40-4350 | O-Ring |
| 1 | 34-40-4475 | Cap Seal |
| 1 | 34-40-4215 | O-Ring |
| 1 | 34-40-4510 | O-Ring |
| 1 | 34-40-4530 | O-Ring |
| 1 | 34-40-4570 | Damping Washer |
| 1 | 42-96-0125 | Bearing Cup |
| 2 | 45-22-0680 | Split Sleeve |
| 1 | 22-18-1355 | Carbon Brush Kit |
| 1 | 49-08-5265 | "S2" Grease, 7oz. Tube |

● **22-18-1355 CARBON BRUSH SERVICE KIT**

THIS KIT CONTAINS:

- | | | |
|---|-------|--------------|
| 2 | ----- | Carbon Brush |
|---|-------|--------------|

FIG.	PART NO.	DESCRIPTION OF PART	NO. REQ.
2	02-04-0911	Ball Bearing	(2)
5	02-08-0640	Ball Bearing	(1)
6	14-46-0040	Vent Kit	(1)
7	02-50-4020	Needle Bearing	(1)
9	05-74-0625	M6 Socket Head Cap Screw	(4)
12	05-88-5910	K35 x 8mm Pan Hd. Plastite Screw	(1)
18	45-22-0680	● Split Sleeve	(2)
20	06-65-1660	Dowel Pin	(1)
24	06-82-8842	Slotted Taptite Torx Screw	(2)
25	05-88-9910	K50 x 22mm PT-DG Screw	(4)
36	14-52-0030	SDS-Max Nose Service Assembly	(1)
37	28-14-2541	Crankcase Assembly	(1)
38	14-46-2565	Gearcase Service Kit	(1)
39	14-09-0160	Crankshaft Assembly	(1)
43	31-12-0040	● 5/8 Cap Plug	(2)
44	31-12-0185	Screw Cap	(1)
48	14-34-0551	Depth Rod Mount Assembly	(1)
49	31-44-2000	Side Handle Housing	(1)
54	31-55-0301	Main Shroud	(1)
55	31-58-0150	Locking Ring	(1)
56	31-86-0100	Spacer	(1)
57	14-08-0200	Clutch Gear Assembly	(1)
58	32-30-0060	Drive Gear	(1)
62	34-40-0240	● Gearcase Seal	(1)
64	34-40-4350	● O-Ring	(2)
65	34-40-4475	● Capseal	(1)
67	34-40-4500	O-Ring	(1)
68	34-40-4510	● O-Ring	(1)
69	34-40-4520	O-Ring	(1)
70	34-40-4530	● O-Ring	(1)
71	34-40-4570	● Damping Washer	(1)
72	34-60-2580	External Retaining Ring	(1)
73	34-80-5010	Retaining Ring	(1)
74	38-50-6250	Spindle	(1)
75	40-50-0370	Shift Spring	(1)
76	40-50-0380	Compression Spring	(1)
80	40-50-8870	Key Spring	(1)
81	42-16-0125	Side Handle Band	(1)
84	42-76-0710	Chuck Collar	(1)
85	42-76-0715	Collar	(1)
87	42-98-0260	Barrel	(1)
88	14-14-0170	Shift Disk Assembly	(1)
89	43-34-0440	Spring Flange	(1)
90	14-34-0516	Side Handle Assembly	(1)
97	43-96-0220	Keys	(2)
98	14-34-0180	Shift Knob Assembly	(1)
101	44-60-1710	Wrist Pin	(1)
102	44-62-0230	Piston	(1)
103	44-82-0220	Ram	(1)
104	44-86-0610	Key Retaining Ring	(1)
105	44-86-0620	Band Retainer	(1)
106	44-90-0005	Seal Retaining Ring	(1)
107	44-90-0175	Shift Ring	(1)
108	44-94-0165	Depth Gauge Rod	(1)
109	44-94-0395	Connecting Rod Assembly	(1)
111	45-06-0555	Dust Seal	(1)
112	45-06-0685	Felt Seal	(1)
113	-----	Spindle Seal	(1)
114	45-30-0060	Retaining Slug	(1)
115	45-56-2640	SDS-Max Striker	(1)
118	45-88-1565	Washer	(2)
119	45-88-4005	Barrel Washer	(2)
121	45-88-7170	Washer	(1)
124	45-88-8730	Wave Washer	(1)
125	14-46-0040	Vent Kit	(1)
126	14-34-0590	Side Handle Assembly Kit	(1)
	48-55-5315	Carrying Case (Not Shown)	(1)

NOTE: Check the clutch torque. Clutch must slip at 40 to 50 ft.lbs. at the spindle, checked clockwise as viewed from the front

▲ SEE BACK PAGE OF THIS BULLETIN FOR ADDITIONAL LUBRICATION AND SERVICE NOTES

Press Needle Bearing (7) in Connecting Rod (109) so that the same amount sticks out on both sides of the Rod.

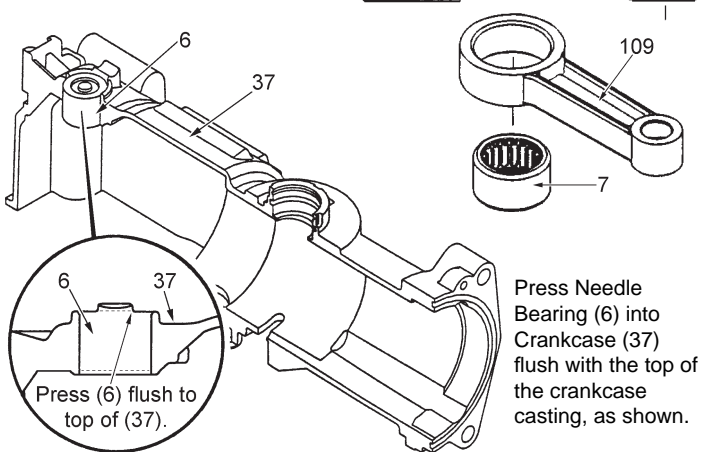

LUBRICATION NOTES: (TYPE "S2" GREASE, NO. 49-08-5265)

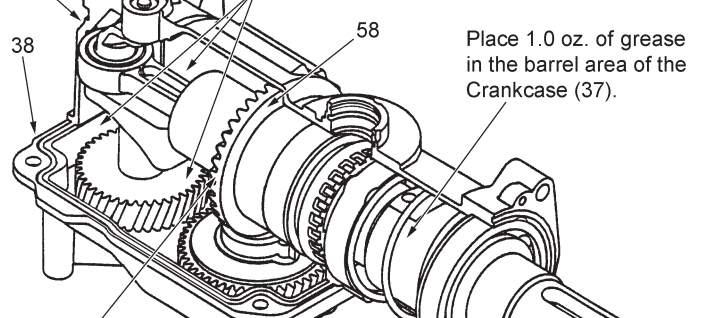
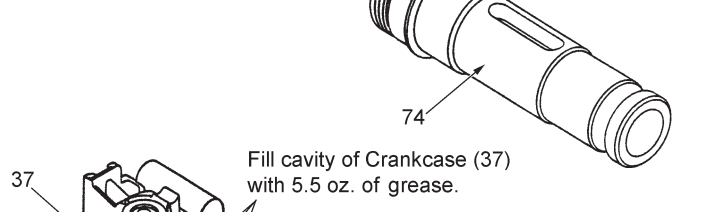
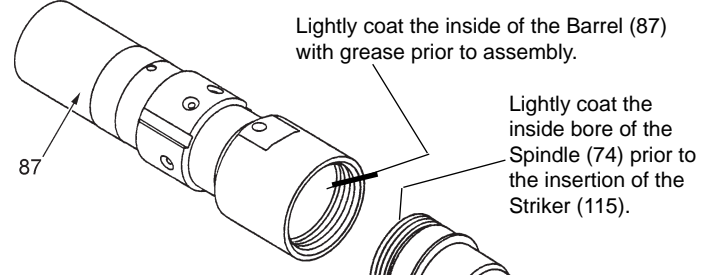
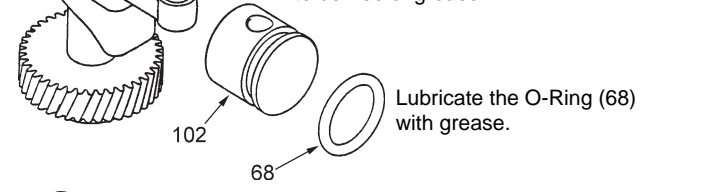
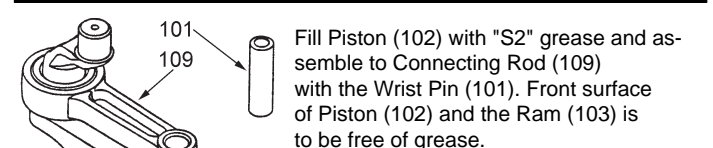

Prior to assembly, apply a light coat of grease to the Gearcase Seal (62) and O-Rings (63, 64, 67, 68 and 70).

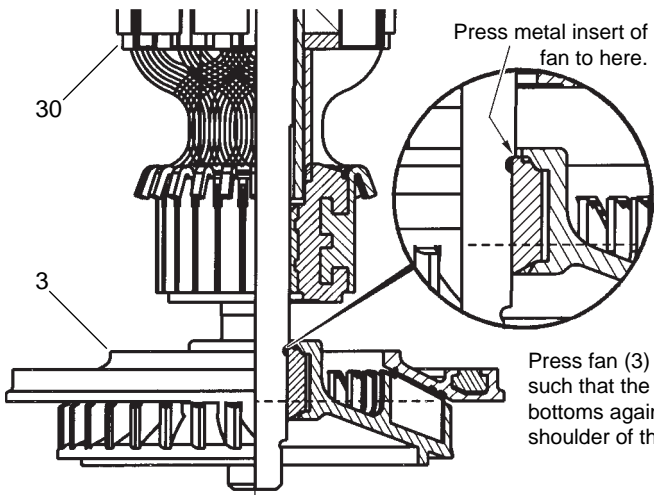

Press fan (3) onto armature (30) such that the metal insert of the fan bottoms against the fan journal shoulder of the armature shaft.

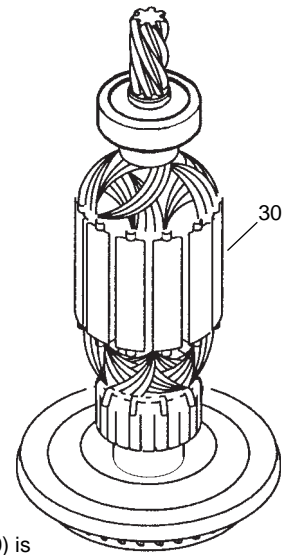

After the armature assembly (30) is installed into the tool, the bearing cup (86) is to be placed on the rear armature bearing (1), (already pressed onto the armature shaft), prior to assembling the motor cover (47) to the tool.

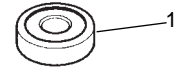

NOTE: Do not dislodge the bearing cup from the bearing during assembly.