



SERVICE PARTS LIST

BULLETIN NO.

55-24-0051

SPECIFY CATALOG NO. AND SERIAL NO. WHEN ORDERING PARTS		REVISED BULLETIN	DATE
1-1/2" ROTARY HAMMER		55-24-0050	Sept. '94
CATALOG NO. 5345-4	STARTING SERIAL NO. 688A	WIRING INSTRUCTION 58-03-0990	

EXAMPLE:
 Component Parts (Small #) Are Included
 When Ordering The Assembly (Large #).

DO NOT WASH OR DEGREASE
CRANK ASSEMBLY

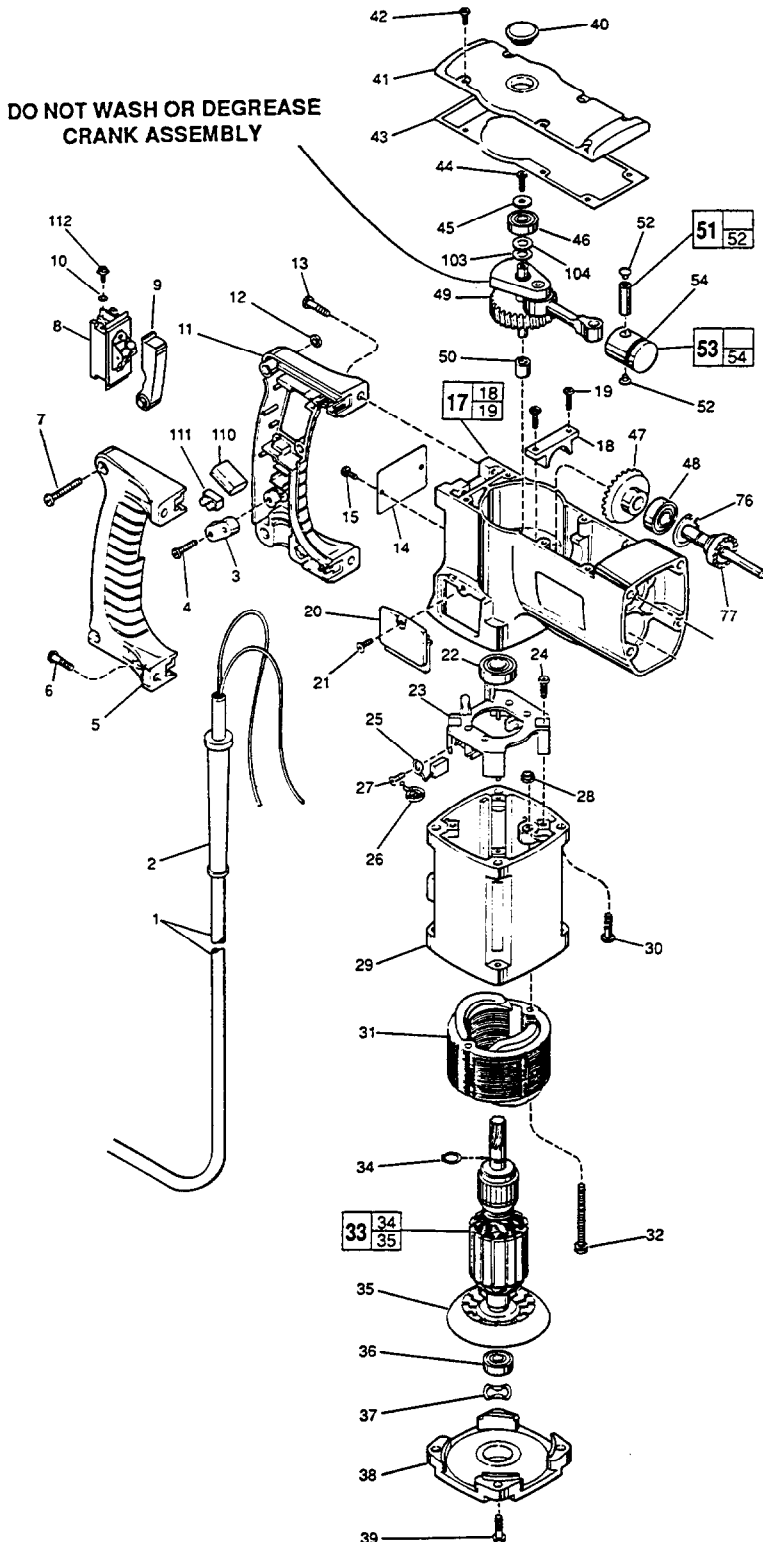

FIG.	PART NO.	DESCRIPTION OF PART	NO. REQ.
1	22-64-4525	Cord Set	(1)
2	44-76-0050	Cord Protector	(1)
3	31-17-0180	Cord Clamp	(1)
4	05-78-0571	M4.55 x 1.59 x 19 Pan Hd. Screw	(2)
5	31-44-1620	Right Handle Half	(1)
6	05-78-0570	M4.55 x 1.59 x 16 Pan Hd. Screw	(2)
7	05-81-0650	M5 x .8 x 25 Pan Hd. Screw	(3)
8	23-66-1230	Switch	(1)
9	31-92-0230	Trigger	(1)
10	06-97-1800	No. 6 Int. Tooth Lockwasher	(4)
11	31-44-1610	Left Handle Half	(1)
12	05-55-0610	M5 x .8 Hex Nut	(3)
13	05-78-0665	M5 x .8 x 20 Pan Hd. Screw	(2)
★ 14	12-20-1020	Service Nameplate Kit	(1)
17	28-14-2182	Crankcase	(1)
18		Bearing Cap	(1)
19	05-78-0460	M4 x .7 x 16 Pan Hd. Screw	(2)
20	31-15-0250	Brush Cover	(2)
21	05-78-0440	M4 x .7 x 10 Pan Hd. Screw	(2)
22	02-04-1203	Ball Bearing	(1)
23	22-22-1450	Brush Carrier Assembly	(1)
24	05-78-0340	M3.63 x 1.34 x 10 Pan Hd. Screw	(2)
25	22-18-0775	Carbon Brush (2) Kit	(1)
26	23-52-1550	Brush Spring	(2)
27	05-78-0405	M4 x .7 x 10 Pan Hd. Screw	(2)
28	06-57-3005	10-32 Locking Hex Nut	(2)
29	31-50-0940	Motor Housing	(1)
30	05-74-0515	M5 x .8 x 20 Socket Hd. Sems	(4)
31	18-54-0160	230 Volt Field	(1)
32	06-81-7470	10-32 x 1-7/8 Pan Hd. Sems	(2)
33	16-54-0160	230 Volt Armature	(1)
34	34-60-0950	Retaining Ring	(1)
35	22-84-0710	Fan	(1)
36	02-04-0850	Ball Bearing	(1)
37	45-88-0577	Wave Washer	(1)
38	31-15-0270	Motor Housing Cover	(1)
39	05-78-0570	M4.55 x 1.59 x 16 Pan Hd. Screw	(4)
40	31-12-0220 ●	Cover Cap	(1)
41	28-20-1311	Crank Case Cover	(1)
42	05-78-0460	M4 x .7 x 10 Pan Hd. Screw	(6)
43	43-44-0650 ●	Gasket	(1)
44	05-78-0440	M4 x .7 x 10 Pan Hd. Screw	(1)
45	45-88-0920	Flat Washer - Spring Steel	(1)
46	02-04-0850	Ball Bearing	(1)
47	32-05-1250	Bevel Gear	(1)
48	02-04-1022	Ball Bearing	(1)
49	14-09-0105	Crank Assembly	(1)
50	02-50-1645	Needle Bearing	(1)
51	44-60-0790	Piston Pin Assembly	(1)
52	42-42-0240	Button	(2)
53	14-46-5000	Piston Assembly	(1)
54	34-40-4090 ●	O-Ring	(1)
76	34-80-2006	Internal Retaining Ring	(1)
77	36-14-0700	Clutch Shaft	(1)
103	45-88-0611	.003 Shim Washer	(1)
104	45-88-0612	.008 Shim Washer	(1)
★ 110	22-33-0420	Suppressor	(1)
111	22-56-0456	Terminal Block	(1)
112	06-95-0125	Switch Terminal Screw	(4)
	10-98-6331	Product Label	(2)

● 14-46-1193 1-1/2" HAMMER SERVICE KIT
THIS KIT INCLUDES:

1	31-12-0220	Cover Cap
1	34-40-4085	O-Ring
2	34-40-4090	O-Ring
1	34-40-4095	O-Ring
1	34-40-4100	O-Ring
1	43-44-0650	Gasket
1	43-44-0670	Gasket
1	43-44-0920	Gasket
1	45-06-0290	Quad Ring Seal
1	49-08-4161	5 Oz. Tube "K" Grease

SEE REVERSE SIDE

MILWAUKEE ELECTRIC TOOL CORPORATION
13135 W. LISBON RD., BROOKFIELD, WI 53005

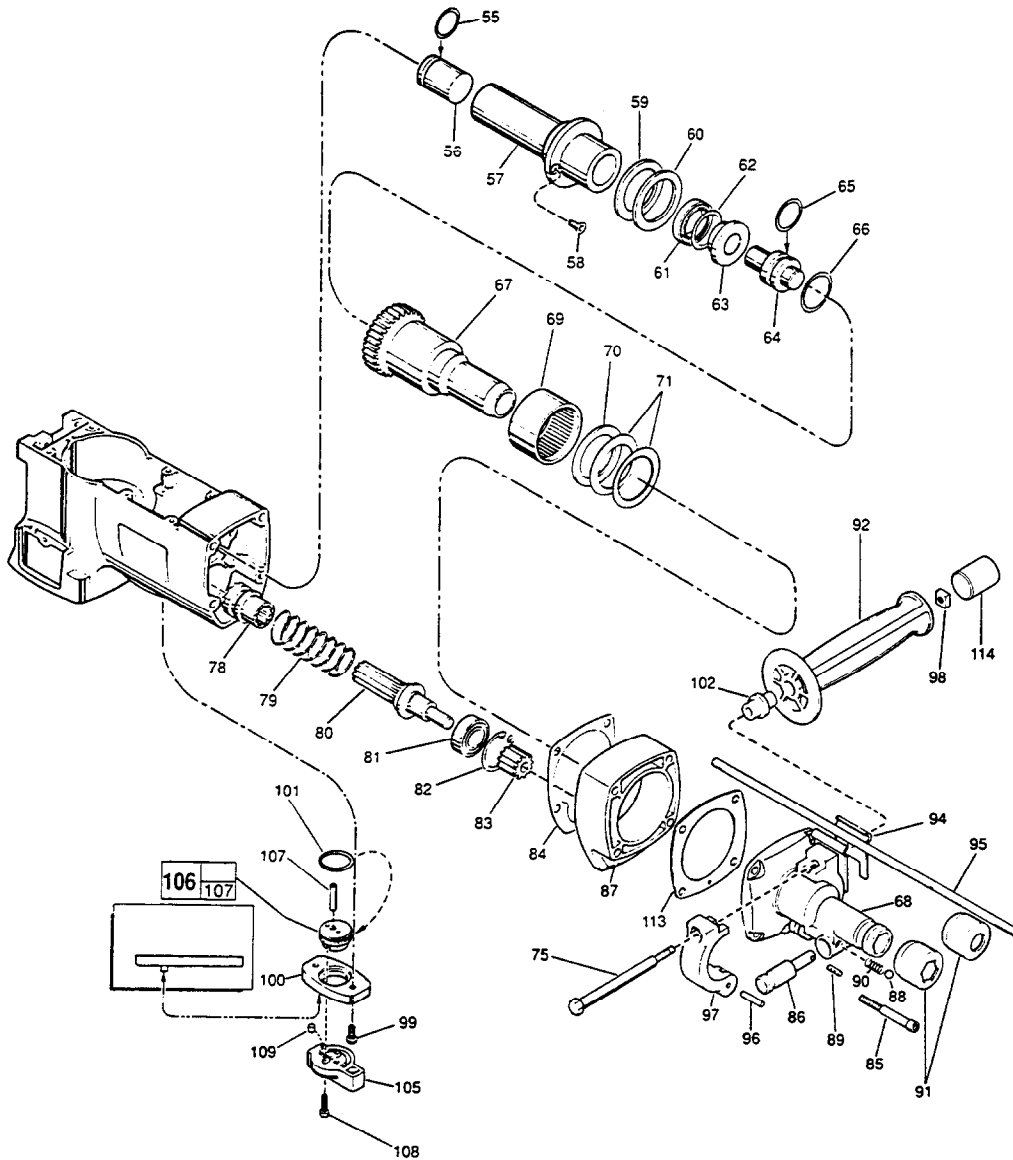

FIG.	PART NO.	DESCRIPTION OF PART	NO. REQ.
55	34-40-4090	O-Ring	(1)
56	44-82-0102	Ram	(1)
57	42-98-0166	Service Barrel	(1)
58	05-78-0435	M4 x .7 x 13 Flat Hd. Taptite Screw	(2)
59	44-90-0562	Damping Ring - Plastic	(1)
60	45-88-7851	Thrust Washer - Steel	(1)
61	45-88-8015	Cushion Washer	(1)
62	34-40-4085	O-Ring	(1)
63	45-88-8020	Cushion Washer	(1)
64	45-56-2551	Striker	(1)
65	34-40-4095	O-Ring	(1)
66	34-40-4100	O-Ring	(1)
67	38-50-5541	Spindle	(1)
68	14-52-0010	Nose Assembly	(1)
69	02-50-9976	Needle Bearing	(1)
70	45-88-0900	Thrust Washer	(1)
71	40-50-7850	Belleville Spring	(2)
75	06-75-0356	5/16 - 18 x 4 Hex Hd. Bolt	(1)
78	36-14-0710	Splined Clutch	(1)
79	40-50-3250	Clutch Spring	(1)
80	14-08-0125	Splined Clutch Assembly	(1)
81	02-04-1510	Ball Bearing	(1)
82	34-80-2355	Internal Retaining Ring	(1)
83	32-60-2160	Pinion	(1)
84	43-44-0670	Gasket	(1)
85	05-74-0650	M6 x 1.0 x 50 Socket Hd. Cap Screw	(4)
86	44-20-0222	Bit Lock	(1)
87	28-14-2220	Intermediate Housing	(1)
88	02-02-0250	1/4" Steel Ball	(1)
89	06-65-0828	Groove Pin	(1)

FIG.	PART NO.	DESCRIPTION OF PART	NO. REQ.
90	40-50-8420	Spring	(1)
91	45-06-0540	Dust Seal-Hex	(1)
	45-06-0550	Dust Seal-Round	(1)
92	43-62-0840	Side Handle	(1)
94	42-68-0390	Depth Gage Clamp	(2)
95	44-94-0165	Depth Gage Rod	(1)
96	06-65-0631	Groove Pin	(1)
97	28-82-0165	Handle Ring Half	(2)
98	06-54-0300	Square Nut	(1)
99	05-78-0440	M4 x .7 x 10 Pan Hd. Screw	(2)
100	44-86-0530	Shift Lever Retainer	(1)
101	34-40-4160	O-Ring	(1)
102	45-36-1160	Spacer	(1)
105	44-10-0150	Shift Lever	(1)
106	14-14-0152	Shift Disc Assembly	(1)
107		Dowel Pin	(1)
108	05-78-0300	M3 x .5 x 16MM Socket Hd. Screw	(2)
109	45-30-0060	Retaining Slug	(1)
113	43-44-0920	Gasket	(1)
114	44-68-0560	Plug-Cap	(1)

FIG. 19,58,87 **NOTES:**
 50 Apply Type 242 Blue Loctite. Torque To 30-35 In.-Lb. Press Flush To Bottom Of Bore (1.845 Deep).
 85 Apply Type 242 Blue Loctite and Torque To 130-140 In.-Lb.

FIG. LUBRICATION
 49 2-1/2 Oz. Type "K" Grease, No. 49-08-4161.
 80 1-1/2 Oz. Type "K" Grease, No. 49-08-4161.
 83 1 Oz. Type "K" Grease, No. 49-08-4161.

Grease All Rubber Parts When Assembling .