



SERVICE PARTS LIST

BULLETIN NO.
54-38-0344

SPECIFY CATALOG NO. AND SERIAL NO. WHEN ORDERING PARTS		REVISED BULLETIN 54-38-0343	DATE May 2005
7" / 9" SANDER - 6000 R.P.M.		WIRING INSTRUCTION 58-01-1308	
CATALOG NO. 6096	STARTING SERIAL NO. 717B		

EXAMPLE:

00	0
----	---

 Component Parts (Small #) Are Included When Ordering The Assembly (Large #)

★ = Part number change from previous service parts list.

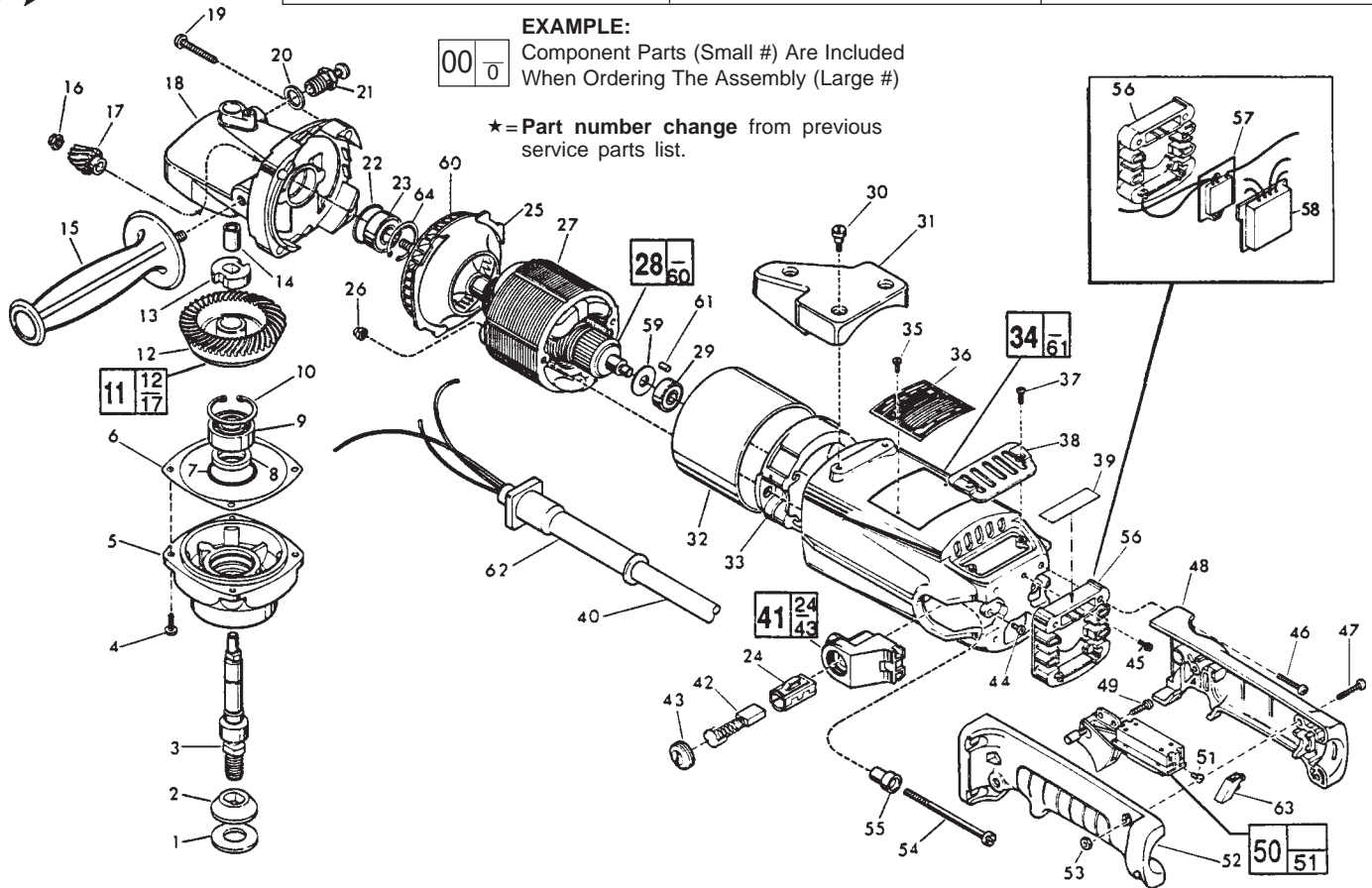

FIG.	PART NO.	DESCRIPTION OF PART	QTY.
1	45-88-8465	Spindle Washer	(1)
2	49-05-0060	Washer Flange	(1)
3	38-50-5560	Spindle Shaft	(1)
4	06-82-8880	10-24 x 5/8" Pan Hd. Taptite, T-25	(4)
5	28-14-1735	Lower Gear Case	(1)
6	45-14-0225	Shim - Blue .005 Thick	(1)
	45-14-0210	Shim - Red .010 Thick	(1)
7	34-40-1550	O-Ring	(1)
8	45-06-0330	Felt Seal	(1)
9	02-04-1745	Ball Bearing	(1)
10	34-80-2960	Retaining Ring - Internal	(1)
11	14-46-4300	Bevel Gear Kit	(1)
12	32-05-2201	Spiral Bevel Gear	(1)
13	42-74-0080	Spindle Locking Cog	(1)
14	02-50-2428	Needle Bearing	(1)
★ 15	43-62-1265	Side Handle	(1)
16	06-57-0500	1/4 - 28 Locking Hex Nut	(1)
17	32-60-1291	Spiral Bevel Pinion	(1)
18	28-14-2035	Upper Gear Case	(1)
19	06-82-5716	1/4-20 x 1-1/4" Pan Hd. Taptite, T-30	(4)
20	45-88-5320	Flat Washer	(1)
21	44-20-0235	Spindle Lock Assembly	(1)
22	34-40-1375	O-Ring	(1)
★ 23	02-04-1860	Ball Bearing	(1)
24	22-20-0360	Brush Tube	(2)
25	42-14-0300	Baffle	(1)
26	06-57-3005	10-32 Locking Hex Nut	(2)
27	18-70-0260	120 Volt Field	(1)
28	16-70-0300	120 Volt Armature	(1)
29	02-04-0913	Ball Bearing	(1)
30	45-04-0720	Shoulder Screw	(3)
31	31-70-0150	Tool Rest	(1)
32	23-16-0950	Insulating Sleeve	(1)
33	31-55-0110	Coil Shield	(1)
34	28-50-6351	Motor Housing	(1)
35	06-82-5270	6-32 x 1/4" Pan Hd. Taptite, T-15	(2)
36	12-99-0408	Nameplate Blank	(1)
37	06-82-3792	8-32 x 3/8" Flat Hd. Taptite, T-15	(2)
38	31-15-0310	Cover Plate	(1)
39	12-98-7270	Instruction Plate	(1)
40	22-64-3000	Cord Set	(1)

FIG.	PART NO.	DESCRIPTION OF PART	QTY.
41	22-22-0401	Brush Holder Assembly	(2)
42	22-18-0730	Carbon Brush Assembly	(2)
43	23-44-0170	Brush Retaining Cap	(2)
44	06-82-7252	8-32 x 3/8" Pan Hd. T-20	(2)
45	06-95-5200	8-32 x 5/16" Slot Hex Hd. Screw	(1)
46	06-82-5584	10-24 x 1-3/8" Pan Hd. Taptite, T-25	(4)
47	06-82-2378	10-24 x 1" Pan Hd. T-25	(3)
48	31-44-0606	Right Handle Half	(1)
49	06-82-7409	8-16 x 1/2" Pan Hd. Plastite, T-20	(1)
★ 50	23-66-1798	Switch	(1)
★ 51	05-78-0305	M 3.5 Switch Screw, T-15	(2)
52	31-44-0607	Left Handle Half	(1)
53	06-55-1050	10-24 Hex Nut	(3)
54	06-82-9600	10-32 x 3-3/16" Field Screw, T-25	(2)
55	31-86-0160	Insulating Bushing	(2)
56	31-86-0190	Insulating Spacer	(1)
57	14-20-0780	Power Module Assembly	(1)
58	14-20-0201	Control Module Assembly	(1)
59	45-06-0390	Dust Seal	(1)
60	22-84-0800	Fan	(1)
61	45-30-0070	Ball Bearing Retaining Slug	(1)
62	44-76-0170	Cord Protector	(1)
63	22-56-0480	Terminal Block	(1)
64	34-80-2600	Internal Retaining Ring	(1)

FIG. NOTES
 6 As Required (Max. .015")
 13 Dimple Side To Fig. 12
 4 Apply type 242 Blue Loctite to threads

FIG. LUBRICATION
 ★ 18 **Important!** Completely clean out old grease from the upper gearcase and replace with 2 Oz. Type "Y" Grease, No. 49-08-5270.