



# SERVICE PARTS LIST

**BULLETIN NO.**  
**55-38-3553**

SPECIFY CATALOG NO. AND SERIAL NO. WHEN ORDERING PARTS		REVISED BULLETIN	DATE
<b>4-1/2" D.I. SANDER-GRINDER</b>		55-38-3552	Sept. 93
CATALOG NO. <b>6140-2</b>	STARTING SERIAL NO. <b>762B</b>	WIRING INSTRUCTION <b>58-01-0309</b>	

**EXAMPLE:**  
Component Parts (Small #) Are Included  
When Ordering The Assembly (Large #).

00 0

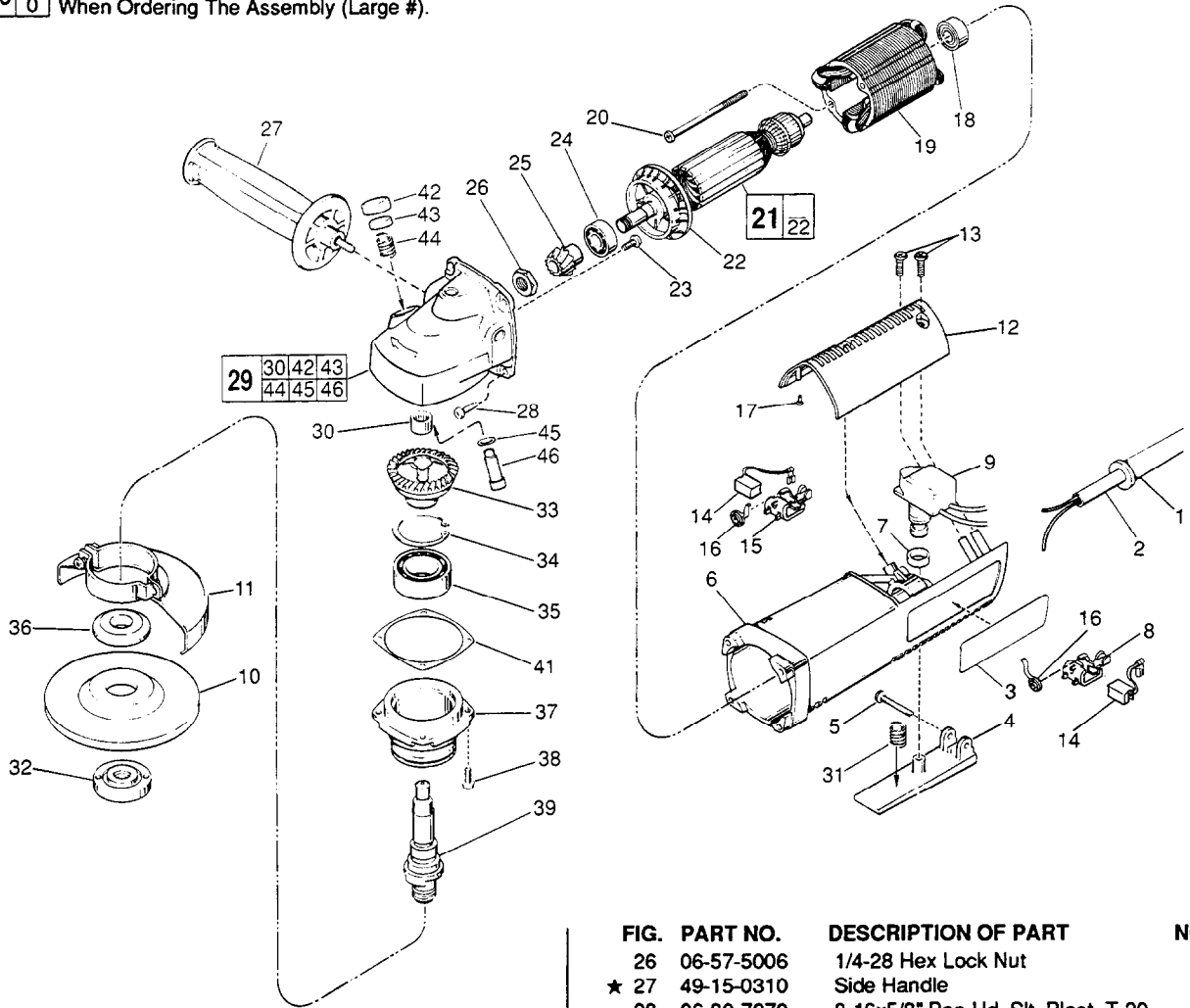

FIG.	PART NO.	DESCRIPTION OF PART	NO. REQ.
	1	44-76-0130 Cord Protector	(1)
	2	22-64-4535 Cord Set	(1)
	3	12-20-1500 Service Nameplate Kit	(1)
★	4	31-92-0112 Trigger	(1)
	5	06-72-0815 .146 Dia. x 1-3/8" Rivet	(1)
	6	31-50-0425 Motor Housing	(1)
	7	44-90-4245 Rubber Ring	(1)
	8	22-20-0691 Left Brush Holder	(1)
★	9	23-66-2170 Switch	(1)
	10	4-1/2" Disc-Select from Catalog	(1)
	11	49-12-0320 Wheel Guard Assembly	(1)
	12	31-15-0142 Cover	(1)
	13	06-82-7270 8-16x5/8" Pan Hd. Slit. Plast. T-20	(3)
	14	22-18-0750 Carbon Brush	(2)
	15	22-20-0692 Right Brush Holder	(1)
	16	23-52-0240 Brush Spring	(2)
	17	42-38-0181 Rubber Bumper	(2)
	18	02-04-0848 Ball Bearing	(1)
	19	18-06-0055 240 Volt Field	(1)
	20	06-82-7375 8-16x2-1/2" Pan Hd. Plast. T-20	(2)
	21	16-06-0060 240 Volt Armature	(1)
	22	22-84-0680 Fan	(1)
	23	06-82-2292 8-32x3/8" Pan Hd. Slit. Taptite T-20	(2)
	24	02-04-1020 Ball Bearing	(1)
	25	32-60-1300 Pinion	(1)

FIG.	PART NO.	DESCRIPTION OF PART	NO. REQ.
	26	06-57-5006 1/4-28 Hex Lock Nut	(1)
★	27	49-15-0310 Side Handle	(1)
	28	06-82-7270 8-16x5/8" Pan Hd. Slit. Plast. T-20	(4)
★	29	14-30-0301 Gear Case Assembly	(1)
	30	02-50-2423 Needle Bearing	(1)
★	31	40-50-1300 Coil Spring	(1)
	32	49-05-0051 Flange Nut	(1)
★	33	32-05-2230 Spiral Bevel Gear	(1)
	34	34-80-2960 Retaining Ring-Internal	(1)
	35	02-04-1746 Ball Bearing	(1)
	36	49-05-0040 Flange	(1)
	37	28-53-0220 Spindle Hub	(1)
	38	06-82-5316 8-32x1/2" Pan Hd. Slit. Taptite T-20	(4)
	39	38-50-5202 Spindle	(1)
	41	45-14-0160 Shim	(0-3)
★	42	31-12-0265 Cap	(1)
★	43	42-42-0075 Lock Button	(1)
★	44	40-50-1300 Coil Spring	(1)
★	45	34-40-4300 O-Ring	(1)
★	46	44-60-1370 Lock Pin	(1)
		49-96-7201 Spanner Wrench	(1)

**FIG. LUBRICATION**

29 1/4 Oz. "O" Grease, No. 49-08-4200.

**FIG. NOTES:**

26 Torque To 60 In./Lbs.

**MILWAUKEE ELECTRIC TOOL CORPORATION**  
13135 W. LISBON RD., BROOKFIELD, WI 53005