



# SERVICE PARTS LIST

**BULLETIN NO.**  
**54-42-6102**

SPECIFY CATALOG NO. AND SERIAL NO. WHEN ORDERING PARTS		REVISED BULLETIN	DATE
<b>1" - 1-5/8" SHARPFIRE</b>		54-42-6101	Jan. 2003
CATALOG NO. <b>6707-20</b>	STARTING SERIAL NO. <b>120C</b>	WIRING INSTRUCTION <b>58-01-1800</b>	

**EXAMPLE:**  

00	0
----	---

 Component Parts (Small #) Are Included  
 When Ordering The Assembly (Large #).

**NOTE: 6707-20 Includes Magazine Attachment No. 48-05-1000. See Reverse Side.**

★=Part number change from previous service parts list.

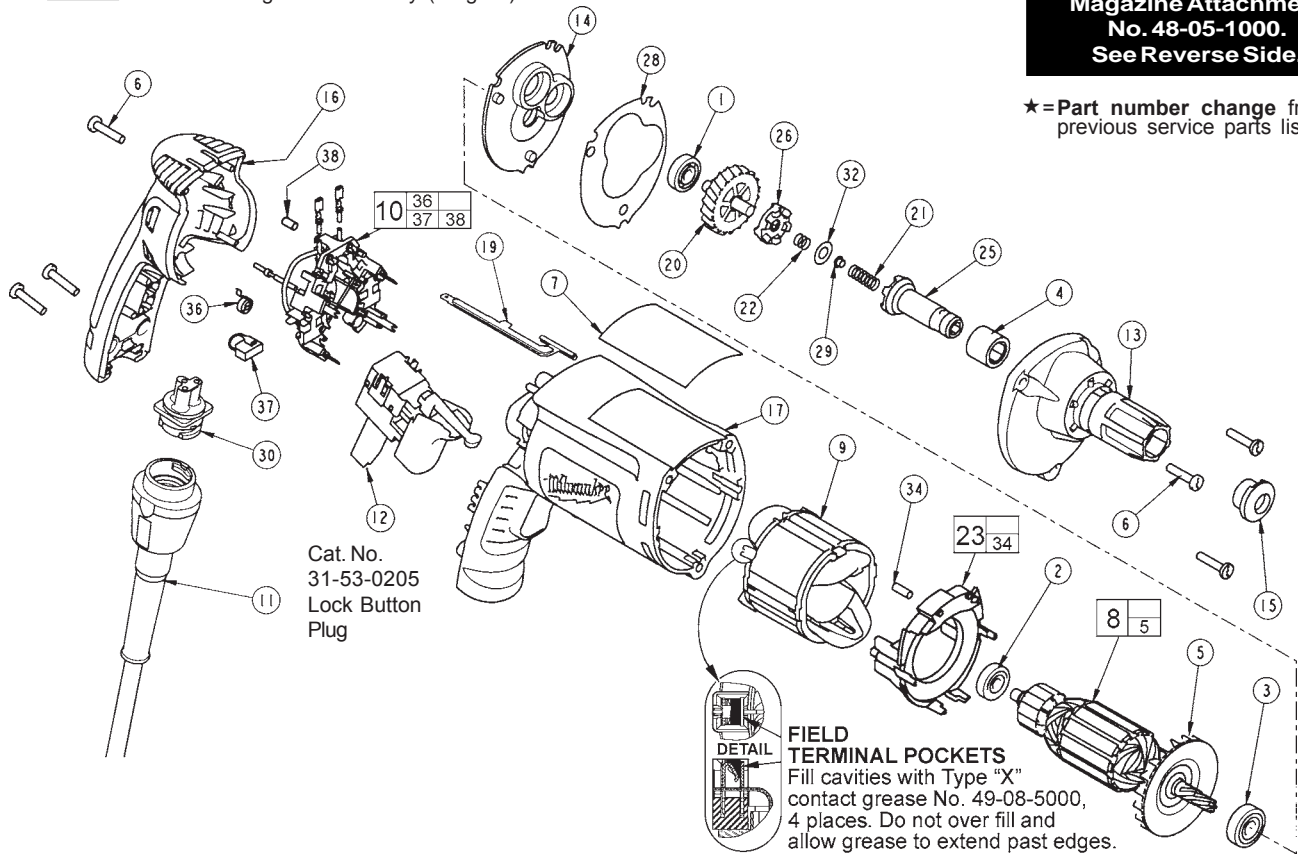

FIG.	PART NO.	DESCRIPTION OF PART	NO. REQ.
1	02-04-0640	Ball Bearing	(1)
2	02-04-0645	Ball Bearing	(1)
3	02-04-0852	Ball Bearing	(1)
4	02-50-3245	Needle Bearing	(1)
5	22-84-0840	Fan	(1)
6	06-82-7275	7-18 x 3/4" Slotted Plastite Torx T-20	(6)
7	12-99-2565	Service Nameplate	(1)
★ 8	16-10-2201	Armature	(1)
9	18-07-2200	Field	(1)
10	22-18-1210	Brush Card Assembly	(1)
11	48-76-4008	Quik-Lok Cord Set	(1)
12	23-66-2585	Switch	(1)
13	28-14-2375	Gearcase	(1)
14	28-28-2315	Diaphragm	(1)
15	30-37-0046	Drywall Nose Guide	(1)
16	31-15-2030	Handle Halve	(1)
17	31-50-2030	Motor Housing	(1)
19	44-60-1700	Ground Pin	(1)
★ 20	32-10-0521	Clutch Gear Assembly	(1)
21	40-50-0095	Separator Spring	(1)
22	40-50-8515	Bias Spring	(1)
23	42-14-0460	Baffle Assembly	(1)
25	42-66-0715	Clutch Chuck Assembly	(1)
26	42-70-0310	Drive Clutch	(1)
28	43-44-0985	Gasket	(1)
29	44-60-0505	Thrust Pin	(1)
30	22-56-1010	Pin Housing Assembly	(1)
32	45-88-0555	Clutch Thrust Washer	(1)
34	45-30-0030	Slug	(2)
36	23-52-1610	Brush Spring	(2)
37	22-18-1310	Brush Assembly	(2)
38	45-30-0035	Slug	(1)

**LUBRICATION (Type "Y" Grease, No. 49-08-5270)**

- Fill the 3 enlarged clutch pockets of the clutch gear assembly (20) with .5 gm. (.02 oz.) grease.
- Apply the same amount of grease in the bias spring (22).
- Apply in total .5 gm. (.02 oz.) grease to the clutch thrust washer (32), thrust pin (29) and separator spring (21).
- Place 7.7 gm. (.27 oz.) of grease at the armature pin location in the gearcase (13) and fill to slightly above the next higher gearcase level.
- Apply a light film of grease to the lead chamfer of the clutch chuck (25) prior to assembly.

**Before assembly, lightly coat all press fit areas with lightweight spindle oil.**

**FIG. NOTES:**

- 4 Needle bearing to have it's seal toward the front of the tool. Needle bearing to be pressed .133/.143 under flush.

**MILWAUKEE ELECTRIC TOOL CORPORATION**  
 13135 W. LISBON RD., BROOKFIELD, WI 53005



# SERVICE PARTS LIST

BULLETIN NO.

SPECIFY CATALOG NO. AND SERIAL NO. WHEN ORDERING PARTS		REVISED BULLETIN	DATE
SCREW-SHOOTER MAGAZINE ATTACHMENT		WIRING INSTRUCTION	
CATALOG NO. <b>48-05-1000</b>	STARTING SERIAL NO. <b>119408022</b>		

EXAMPLE:

00  
0

Component Parts (Small #) Are Included When Ordering The Assembly (Large #).

★ = Part number change from previous service parts list.

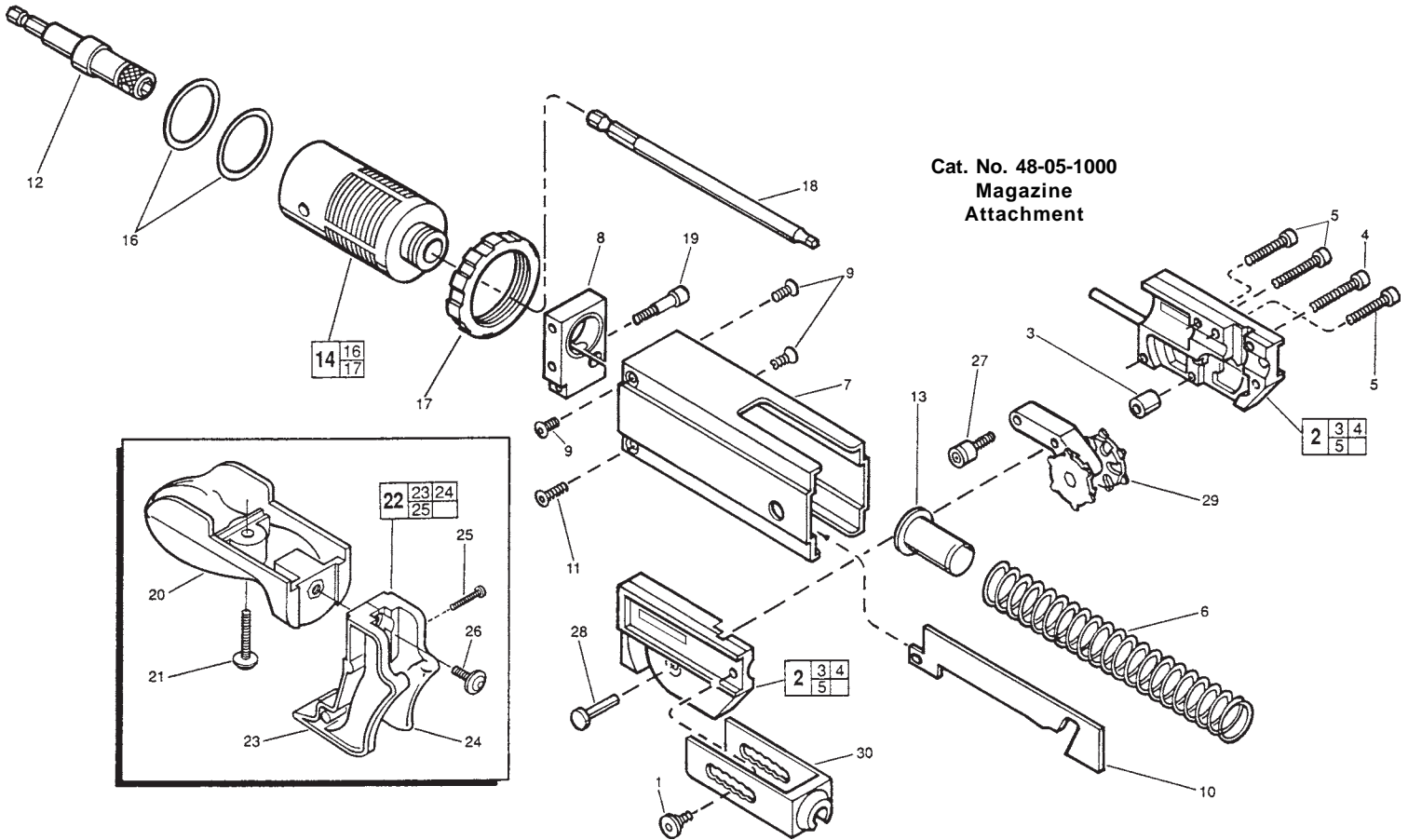

Cat. No. 48-05-1000  
Magazine  
Attachment

FIG.	PART NO.	DESCRIPTION OF PART	NO. REQ.
	1	06-81-1700 M5 x 0.8 x 5. lg, 3mm Skt. Hd. Slid. Sc.	2
★	2	43-56-0315 Gliding Assembly (Incl. 3,4,5)	1
	3	42-40-0001 Distance Bearing Bushing	1
★	4	06-95-1000 M3.5 x 22. lg, Phillips Pan Hd. Plast. Sc.	1
★	5	06-95-1005 M3.5 x 24. lg, Phillips Pan Hd. Plast. Sc.	3
	6	40-50-0405 Spring (Blue)	1
	7	43-76-0050 Housing	1
	8	44-66-1500 Mounting Plate	1
	9	06-81-2000 M4 x 0.7 x 8. lg, 2.5mm Skt. Hd. Flat Sc.	3
	10	44-66-0305 Curve Plate	1
	11	06-81-2005 M4 x 0.7 x 10. lg, 2.5mm Skt. Hd. Flat Sc.	1
	12	43-72-0010 Bit Holder	1
	13	43-56-0300 Spring Guide	1
★	14	43-76-0296 Adapter Assembly	1
	16	34-40-0700 O-Ring	2
	17	44-40-0575 Stop Nut	2
	18	48-30-1521 120mm #2 Phillips Bit (Not Shown)	1
	18A	48-30-1526 120mm #2 Square Bit	1
	19	06-81-2010 M5 x 0.8 x 25. lg, 4mm Skt. Hd. Slid. Sc.	1
	20	43-62-1230 Handle	1
	21	06-81-2015 M5 x 0.8 x 25. lg, 3mm Skt. Hd. Slid. Sc.	1
	22	43-56-0305 Plastic Belt Guide (Incl. 23,24,25)	1
	23	43-56-0320 Belt Guide-Right	1
	24	43-56-0325 Belt Guide-Left	1
	25	06-95-1010 Assembly Guide Screw	2
	26	06-81-2020 M5 x 0.8 x 12 lg, 4mm Skt.1 Hd. Pan Sc.	1
	27	06-81-2025 M5 x 0.8, 3mm Socket Hd. Roller Screw	1

FIG.	PART NO.	DESCRIPTION OF PART	NO. REQ.
	28	44-60-1520 Pivot Pin	1
	29	42-74-0095 Gear Wheel Unit	1
★	30	43-46-0207 Depth Control, 1" to 2-1/4"	1
		49-96-4800 Hex Key Set-2, 2.5, 3 & 4mm (Not Shown)	1
		10-15-6100 Depth Label (Not Shown)	1
		12-25-1470 Warning Label (Not Shown)	1

**FIG. NOTES:**

9,11 Use Loctite 272 on screws.

MILWAUKEE ELECTRIC TOOL CORPORATION  
13135 W. LISBON RD., BROOKFIELD, WI 53005